

# Lightning Overvoltage performance of 132kV GIS Substation in Malaysia

Ab. Halim Abu Bakar, Hazlie Mokhlis, Lim Ai Ling , Hew Wooi Ping

**Abstract-** Over voltages are phenomena present in all networks. They can be created externally or internally. Over voltages which can appear on the system for which the equipments are intended to operate is the basis of the selection of the strength of the equipment known as Insulation Coordination especially for voltages less than 275kV. Recently a Gas Insulated Substation (GIS) in Kuala Lumpur undergone overhaul. A study was carried out to investigate the lightning over voltages that affect the GIS Substation. The objective of the study was to determine whether the withstand capability or Basic Insulation Level (BIL) was the cause of the fault occurring in the substation.

**Index Terms-** Over voltages, Bergeron model, Frequency dependent model,

## I INTRODUCTION

Malaysia, having a very high number of thunderstorm days per year, at 220 days per year and recorded flash density of 20 flashes/km/year would typically experience over voltages due to lightning strikes. The lightning over voltages are mostly caused by a back flashover .Once contact is made with the line, the injection of the lightning return stroke current is modelled as a transient current generator feeding into a system of transient surge impedances representing the line conductors and the tower. The resulting over voltages are then calculated using conventional travelling wave techniques, usually considering mainly the line spans close to the struck towers. [1]

Shielding failure occurs when lightning strikes of 20 kA and below bypass the overhead shield wire. Back flashovers occur when lightning strikes the tower or the shield wire and the resultant tower top voltage is large enough to cause flashover of the line insulation from the tower to the phase conductor. Induced over voltages in the phase conductor caused by strokes to ground in close proximity may happen too but they are generally below 200kV [1] and are important only to lower voltage systems. The minimum transmission voltage is 132kV and the BIL is 650kV. Due to this and also because the lightning current in Malaysia is typically more than 20kA,

only back flashes shall be evaluated in this simulation and not induced over voltages or shielding failures. Moreover, back flashes are more severe. Transient over voltages may also be caused by switching operations but for voltages lower than 300kV no problem correlated with operating switches has occurred [2] so it will not be investigated here as the voltage level at the Substation is 300kV maximum. Many utilities have carried out similar insulation coordination studies on their installations. [3],

4], [5]. This paper presents a study on the over voltage effects experienced in a 132V GIS at KL Substation in Kuala Lumpur,

The objectives of this study are:

- i) to perform an over voltage assessment of the substation due to lightning surge.
- ii) to evaluate the types of travelling wave models used for the substation and overhead lines.
- iii) to investigate the protective level of the substation equipment

## II. MODELLING

The overall substation models are derived from the substation layout drawings. Reference [6] is used as the basis of most of the models. Of particular interest is the transmission line models as they make up the bulk of the simulation model. They are used for the towers, conductors and GIS bus ducts. Three models are available in PSCAD but only the Bergeron and the frequency dependent (phase) model will be implemented because the frequency dependent (mode) model is not suitable for multiphase and untransposed transmission lines. The incoming 132kV double circuits are placed on a quadruple circuit tower and also 132V double circuit towers. In this study only the 132kV quadruple circuit towers will be used.

The overhead lines are represented by multi phase model considering the distributed nature of the line parameters due to the range of frequencies involved. Phase conductors and shield wires are modelled in detail between the towers. Only back flash are considered as the shielding angle is zero and also the current magnitude is greater than 20kA [1]. For the back flash, the initial line voltage and polarity are of importance therefore a custom model for the power

frequency effect is included in the model. The variation of the tower footing resistance taking into account the soil ionization is also considered.

*A Tower Modelling*

The towers are modelled as single conductor distributed parameter line (Bergeron model travelling wave) segments of ‘transmission lines’ in PSCAD. The tower model is constructed geometrically similar to that of the physical tower. The tower is terminated by a resistance representing the tower footing impedance. For the insulator strings, it is modelled as a capacitance in parallel with a circuit breaker across the gap. If there is a back flash, it is simulated as the closing of the circuit breaker (green changes to red colour). Part of a tower model is shown in Figure 1

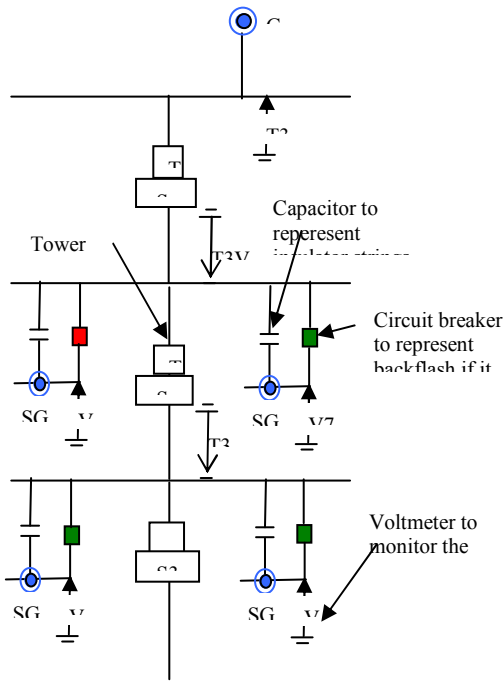

Fig. 1 PSCAD Tower Model

The overhead line phasing is modelled in detailed in PSCAD to show the flashover occurrence dependence on power frequency effect. Figures 2 shows the line configurations defined in the PSCAD simulation model for the circuits entering substation. When using the frequency dependent (phase) model, this conductor geometry (conductor dimensions, spacing, bundling, heights etc) are necessary since they play a part in determining the frequency dependent surge impedance and propagation characteristics. When using the Bergeron model, since the line parameters are constant at the chosen frequency, the user may enter the R, L and C values manually. The overhead lines are modelled as the Bergeron Model and

the Frequency Dependent (Phase) Model to compare the difference in the surge voltage. The number of spans modelled are three spans of 300m each and the third span is taken as an infinite line to account for no reflections from the distant end.

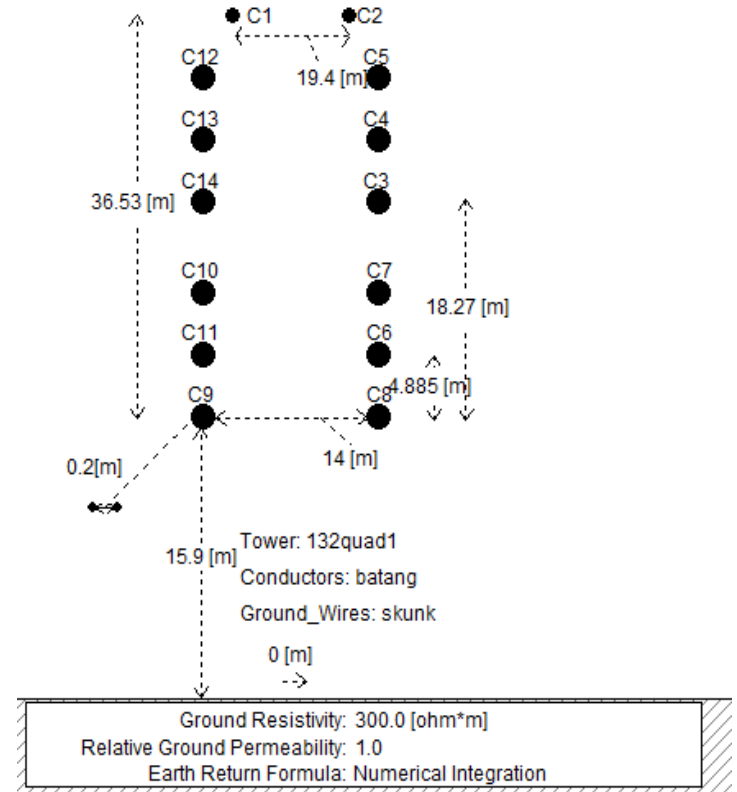

Fig. 2 132kV quad tower for Kg Lanjut and Segambut circuit

*1 Power Frequency Effect*

In addition to the voltage caused by the lightning strike, the system voltage at power frequency adds or subtracts to the actual voltage across the insulator depending on which part of the sine wave the system voltage is at during the time of strike on the groundwire. In order to cater for this effect, a custom module ‘power frequency effect’ is added to the leader progression model which calculated the effective voltage to determine if a backflash will occur across the insulator string or not.

*2 Line Insulator Flashover*

The wide variety of lightning stroke characteristics, together with the modification effects which the power system components have on the impinging current surges stress the insulation structures with a diversity of impulse voltage shapes. The traditional model for insulator

flashover is using the measured volt-time curve which have been determined empirically for a specific gap or insulator string using the standard 1.2/50  $\mu\text{s}$  wave shape. However, since the insulator string is subject to non-standard impulse wave shapes, the empirical volt-time curves bear little resemblance to the physical breakdown process. A better model is the leader progression model .

### 3 Leader Progression Model

In the leader progression model, the discharge development consists of corona inception, streamer propagation and leader propagation. When the applied voltage exceeds the corona inception voltage, streamers propagate and cross the gap after a certain time if the voltage remains high enough. The streamer propagation is accompanied by current impulses of appreciable magnitude. Only when the streamers have crossed the gap can the leaders develop to a significant extent. The leader velocity will increase exponentially. When the leader or leaders bridge the insulator gap, then the breakdown occurs.

The backflash occurs when the voltage equals or exceeds the line critical flashover (CFO) voltage across the insulator string and is used as the condition check to determine whether the current leaders are formed or otherwise. The calculation procedure consists of determining the velocity at each time instant, finding the extension of the leader for this time instant, determining the total leader length, and subtracting this from the gap spacing (insulator length) to find a new value of  $x$ . This process is continued until the leader bridges the gap. When this happens, the breaker will close to indicate that a backflash has taken place.

### 4 Tower Footing Resistance

High magnitudes of lightning current, flowing through the ground resistance, decrease the resistance significantly below the low-current values. When the gradient exceeds a critical gradient  $E_o$ , breakdown of soil occurs. As the current increases, streamers are generated that evaporate the soil moisture which in turn produces arcs. Within the streamer and arcing zones, the resistivity decreases from its original value and as a limit approaches zero and becomes a perfect conductor. In the TFR model, the user inputs are  $E_o$  and  $R_o$  (the DC resistance) as measured at site. The module then calculates the effective resistance of the ground rod according to the IEEE std 80 2000. Figure 3 shows the decrease of resistance from 50ohms at low frequency to  $R_i < 15$  ohms during the strike. This is proven by calculation with  $E_o = 400\text{kV/m}$ ,

$R_o = 50\text{ohms}$ ,  $\rho = 300\text{ohm.m}$ ,  $I_R = 100\text{kA}$  at peak to give  $R_i = 13.3$  ohms

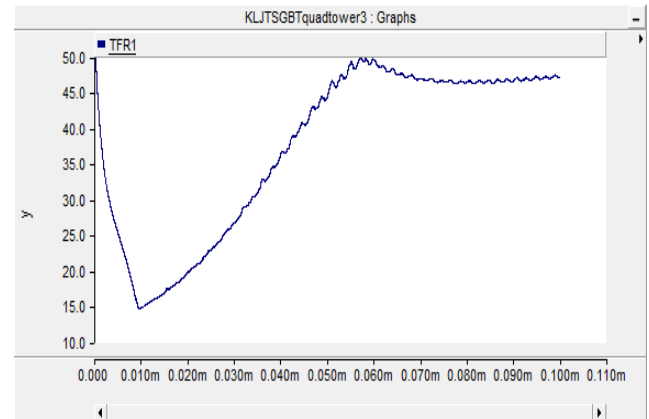

Fig .3 Variance of Tower Footing Resistance

### 5 Concave wave shape

The triangular wave shape is very simplistic. For a more realistic representation, the CIGRE concave wave shape usually gives more realistic results. Figure 4 gives the concave wave shape characteristics which resembles more like the actual wave shape .

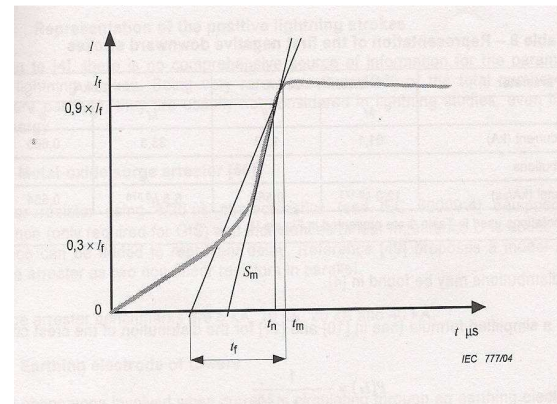

Fig. 4 CIGRE concave shape,

$I_f$  is the crest current,  $S_m$  is the maximum front steepness,  $t_f$  is the equivalent front duration.

### B Substation Modelling

The overall substation models are derived from the substation actual layout. A site visit was made to obtain the arrangement of the circuit bays and to take measurements (length and diameter) of the dimensions of the GIS equipment.



Fig. 5 132kV GIS

### 1 GIS busducts

According to [7], GIS busducts are modelled as lossless transmission lines with distributed parameters which is the Bergeron model. The frequency dependent (phase) model cannot be used for the GIS as it requires conductor and tower data such as conductor radius, tower height, bundle spacing. The GIS busducts which are a concentric cylindrical shape are modelled as untransposed line sections in distributed parameter

Since the surge impedance of the single phase bus duct and single core cable are similar, therefore it is assumed that the surge impedance of the 3 phase encapsulated busduct is similar to that of a 3 core cable. Referring to [8], The surge was considered to have a propagation speed of 285,000,000m/s which is the 0.95 times the velocity of light [7]. Since the surge impedance of the gas insulated buswork is considerably smaller than the surge impedance of the overhead conductors, travelling wave reflection at the gas- air interface could rapidly result in sizable over voltages at the open disconnect position within the gas insulated buswork and thus the lumped model is not used for the gas insulated buswork. In the PSCAD simulation model, the Bergeron model with reflection option enabled is used to represent the gas insulated bus works as well as the overhead lines. The Bergeron model represents the L and C elements of a PI section in a distributed manner and is accurate only at the specified frequency. Simulations will be tried out at 10 kHz, 500kHz and 3MHz to compare any difference .However, transmission lines are recommended to be modelled at 500kHz for lightning studies to account for the skin effect.[6] The simulation is repeated with the overhead lines using frequency dependent (phase) model to compare any difference in the results.

## 2 Bergeron model parameters

In the following Bergeron parameter input model, the values of R, travel time, surge impedance are able to be entered manually. For short distances, the line is considered as 'not reflectionless' to enable reflections for more accurate simulation of over voltages caused by reflections at change of impedances or discontinuities. The travel time interpolation is also set to be 'on' because of the short lengths involved,

## 3 Spacers

According to [2] , the influence of spacers supporting the conductors can usually be neglected but in this case, an additional capacitance of 20pF for the spacers are accounted.

## 4 Circuit breakers and Disconnectors

Circuit breakers in the closed position are modelled by PSCAD as a path of low resistance. In the open position a capacitance of 10pF is placed across the contacts of the circuit breaker and disconnector. This is shown in Figure5.

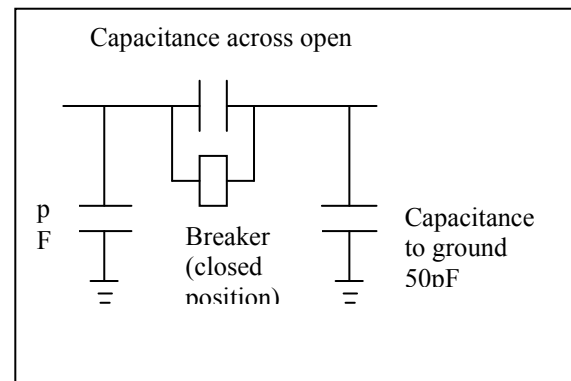

Fig.6 Circuit Breaker and Disconnecter

## 5 Surge Arresters

The Metal Oxide Surge Arrester is modelled as a non linear resistor in series with a variable voltage source in the PSCAD library. Interpolation techniques are used for switching between linear pieces of the I-V characteristic for best accuracy. The user may enter the I-V characteristic directly, read the I-V data from an external file. In this simulation the I-V data is entered directly. The data to be entered is the maximum discharge in p.u. for the 8/ 20  $\mu$ s current wave.

### III. RESULTS AND DISCUSSIONS

Simulations were carried out with different overhead line models, lightning impulse wave shapes and different frequencies (for Bergeron models). A time step of  $0.005 \mu\text{s}$  is used to give the minimum length of 1.5m to cater for the GIS segments. The total simulation time is  $100 \mu\text{s}$ . In this simulation, the Bergeron model is used for the overhead lines and the GIS. The simulation parameters chosen are

- i) Frequency 500 kHz as recommended in [6].
- ii) The impulse wave shape is concave with amplitude of 100kA time to half of  $75 \mu\text{s}$ , and the front time is  $4.5 \mu\text{s}$  as calculated using the log normal distribution. The value was chosen to obtain a double circuit flashover based on a previous record of such an event at the Kuala Krai - Gua Musang 132kV line, [9].
- iii) The strike is to the ground wire at tower no. 3 of 132kV quad tower causing back flash since  $I > 20\text{kA}$  (back flash domain as per [4]).
- iv) The tower footing resistance is 10ohms at low frequency.
- v) Power frequency effect is  $270^\circ$  phase shift.

#### A Simulation result

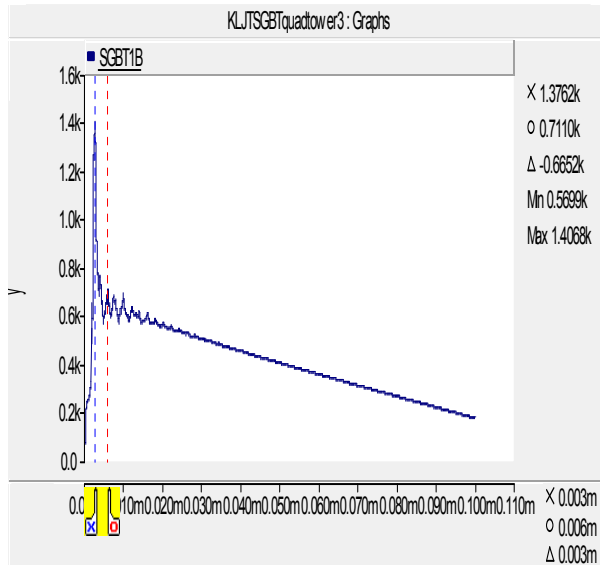

Fig. 7 Surge voltage at SGBT1Y(C4) conductor

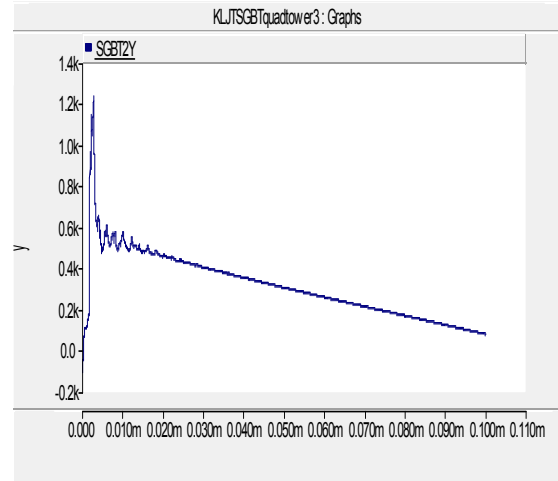

Fig. 8 Surge voltage at SGBT2Y(C13) conductor

Flashover occurs at SGBT1Y(C4) yellow phases and SGBT 2Y(C13) yellow phase. This means the leaders have bridged the insulator gap for these two phases. The surge voltages at the SGBT1Y (C4) and SGBT2Y(C13) conductors as in Fig. 7 and 8 are similar in shape. The peak voltage occurs at about  $10 \mu\text{s}$  because of the leader progression time, i.e. the time it takes for the streamers to bridge the insulator gap which has been set to 1.3m for the 132kV circuit. This surge voltage is recorded voltage rise phase to ground above the power frequency voltage i.e. for SGBT1Y (C4) the crest is 30kV maximum above 76kV phase-ground and for SGBT2Y (C13) the maximum surge voltage is 55kV above 76kV phase to ground.

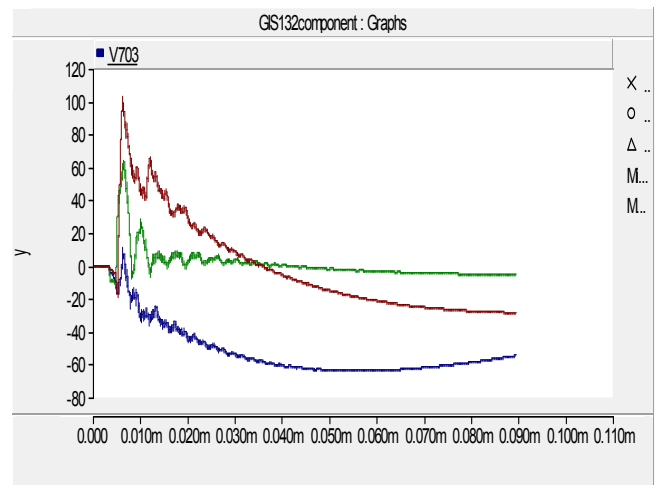

Fig.9 Surge voltage at the GIS entrance of SGBT1 (C4) with the SGBTY1 line disconnector open

When the line disconnector is opened, the reflections at the open position increase the surge voltage at the GIS entrance from 30kV crest to about 100kV as in Fig 9.

### B Frequency dependent (phase) model for the overhead lines

The frequency dependent (phase) model will model the line parameters in the phase domain. The frequency dependent line parameters should make the surge voltage waveform more accurate because the line parameters are more accurately calculated over the range of frequency which has been set from 10,000 Hz to 3 MHz. All other simulation settings are the same .

### C Simulation results for frequency dependent model

The flashover phases are SGBT2Y(C13) and SGBT1Y. (C4) However Fig.10 and 11 show that the surge waveforms at the tower conductor flashover display multiple reflections after the crest of the impulse.

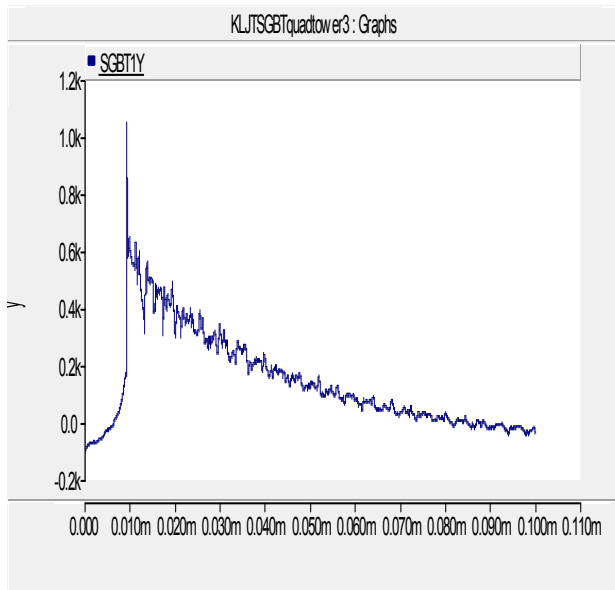

Fig.10 Surge voltage at SGBT1Y (C4) conductor at the struck tower

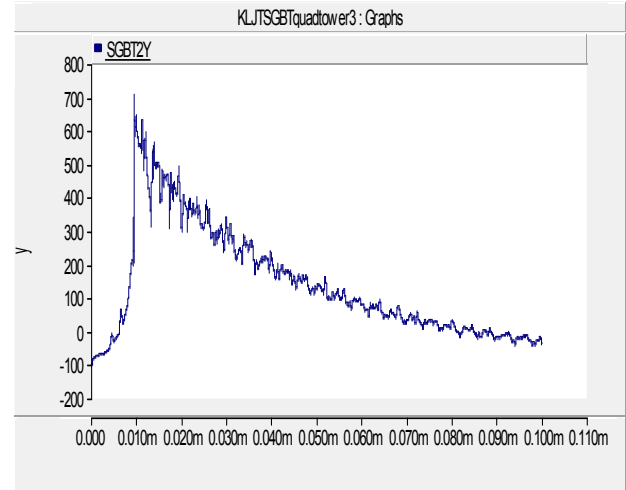

Fig.11 Surge voltage at SGBT2Y (13) conductor at the struck tower

Using the frequency dependent model in the phase domain accurately models the impedances over a range of frequencies thus it can be seen that the small voltage surges still appear in the tail of the impulse voltage unlike the Bergeron model which gives a smoother tail. The crest voltages using the frequency dependent model is also slightly lower .

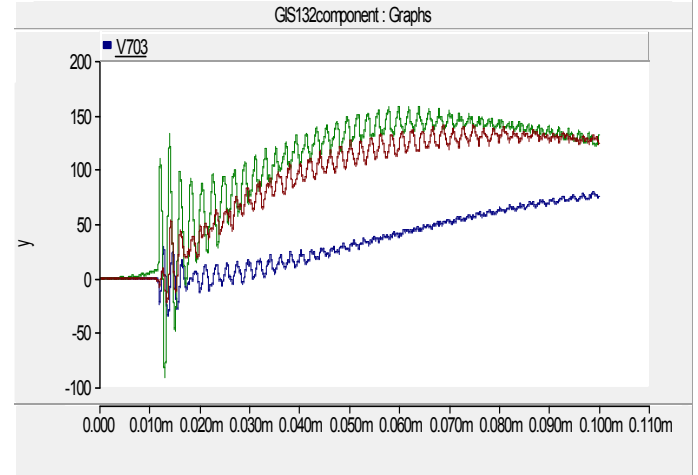

Fig.12 Surge voltage at the line entrance to the GIS when the line disconnector is closed for SGBT1Y(C4)

When Fig. 12 is compared to Figures 13 it can be seen that when using the frequency dependent (phase) model for transmission lines

- i) the maximum voltage is higher
- ii) the voltage reflections continue for a long period



- iii) there are more voltage oscillations ‘mini peaks’ are more defined
- iv) the reflections after the initial transient could reach a higher voltage than the initial peak.

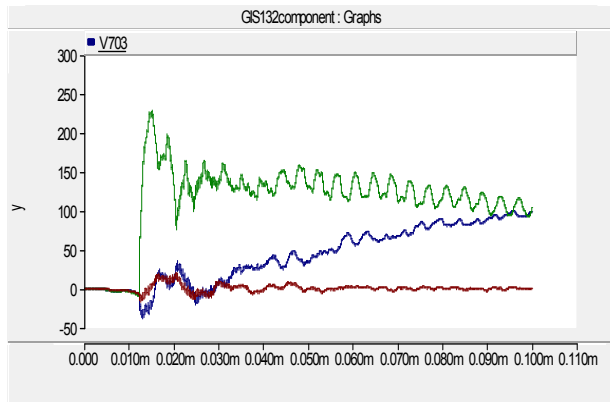

Fig. 13 Surge voltage at the line entrance to the GIS when the line disconnector is open for SGBT1Y(C4)

#### IV. CONCLUSION

From the simulations presented the following conclusions can be drawn :

a) The Bergeron and frequency dependent (phase) models show slightly different voltage back flash waveforms at the same monitoring position even though the lightning strike impulse wave applied is identical. This is due to the formulation of the line surge impedances at a constant frequency (Bergeron) versus variable surge impedance (frequency dependent) in the two models. The difference can be seen especially in the tail of the voltage waveform where the simulation using the frequency dependent model produces well defined reflection peaks whereas the Bergeron simulation produces a waveform that has a relatively smooth tail. The modelling of the transmission lines with the frequency dependent (phase) model is recommended over the Bergeron model to accurately simulate the line constants which vary with frequency. Since the travelling waves between towers are highly oscillatory, a wide range of frequencies are involved therefore using the Bergeron model at an unsuitable frequency may lead to inaccuracies in the peak voltage and the transient response of the system to the flashover. When using the frequency dependent models, the phase domain model should be used because the transmission lines in Malaysia are not transposed and are multiphase therefore the modal model will not accurately decouple the multi phases into single phase conductors.

d) The design of the GIS appears to be adequate as the surge voltages are within limits as it is limited by the protective function of the surge arrester. Even with reflection from an open disconnector the effect of ‘voltage doubling’ still does not bring the peak voltage above the protective margin of the GIS design. The protective margin of the GIS is design is  $650\text{kV}/1.2 = 542\text{kV}$ .

#### REFERENCES

- [1] CIGRE Working Group 33.01, "Guide to Procedures For Estimating The Lightning Performance of Transmission Lines, Technical Brochure 63, 1991
- [2] CIGRE Working Group 33/13-09, Very Fast Transient Phenomena Associated With Gas Insulated Substations, 1988 Session, 28<sup>th</sup> August
- [3] S.Lam-Du, T.Tran-Quoc, T.Huynh-Van, J.C. Sabonnadiere, H.Vo-Van-Huy, L. Pham-Ngoc, "Insulation Coordination Study Of A 220kV Cable Line".
- [4] P.C.V. Esmeraldo F.M Salgado Carvalho, Surge Propagation analysis : An Application To the Grajau 500kV SF6 Gas Insulated Substation, CIGRE 1988 Session 28<sup>th</sup> August – 3<sup>rd</sup> September
- [5] T.Kawamura, Y.Ichihara, Y.Takagi, M.Fujii, T.Suzuki,, Pursuing Reduced Insulation Coordination For GIS Substation By Application Of High Performance Metal Oxide Surge Arrester, CIGRE 1988 Session 28<sup>th</sup> August – 3<sup>rd</sup> September
- [6] Modelling Guidelines for Fast Front Transients, IEEE Transactions on Power Delivery, Vol. 11, No. 1, January 1996.
- [7] IEC TR 60071-4, First edition 2004-06.
- [8] Electric Cables Handbook, 3<sup>rd</sup> Edition, BICC Cables , pages 11 and 14.
- [9] Ab Halim et.al., "Economic positioning of Line lightning Arresters," Cigre Symposium Zagreb Croatia 18-21 April 2007 Transient Phenomena of Large Electric Power System