

Advances and challenges in grid tied photovoltaic systems



SeyedMohsen Mirhassani^a, Hwai Chyuan Ong^{a,*}, W.T. Chong^a, K.Y. Leong^b

^a Department of Mechanical Engineering, Faculty of Engineering, University of Malaya, Kuala Lumpur, Malaysia

^b Department of Mechanical Engineering, Universiti Pertahanan Nasional Malaysia, Kem Sungai Besi, 57000 Kuala Lumpur, Malaysia

ARTICLE INFO

Article history:

Received 5 April 2014

Received in revised form

20 March 2015

Accepted 24 April 2015

Available online 14 May 2015

Keywords:

Grid connected photovoltaic system

Renewable energy

Voltage quality

Cost study

PV energy

ABSTRACT

Photovoltaic (PV) technology is gathering momentum around the world. Global PV energy harvest has been more than doubled since 2010. Grid connected PV (GCPV) systems can be found in different scales classified into three categories of small scale, medium scale and utility scale. Considering size of the system various configurations are suggested for the GCPV systems while each configuration might be assessed by factors such as efficiency, reliability, expandability and cost. Moreover, high integration of GCPV systems into the power system network creates several technical problems mostly coming from the intermittent nature of solar energy. In addition, to achieve a higher degree of power system reliability, GCPV systems are required to support the grid in abnormal condition such as faults and deviation from standard frequency. This paper provides a comprehensive review on GCPV systems. Various configuration proposed by the literature will be discussed. Cost study and impact of technical and environmental factors on the total expense and revenue of GCPV installation will be investigated. Different aspects of PV integration into the power network will be discussed. Problem and solutions will be studied as well. Finally grid requirements and active and reactive power support will be reviewed.

© 2015 Elsevier Ltd. All rights reserved.

Contents

1. Introduction	122
2. Cost study	122
3. System configuration	123
4. Voltage and power qualities	125
4.1. Voltage rise	125
4.1.1. Active power curtailment	125
4.1.2. Reactive power control	125
4.1.3. Energy storage system	126
4.2. Voltage fluctuations and unbalance	126
4.3. Harmonics	126
4.3.1. Passive filters	127
4.3.2. Active strategies	127
5. Grid codes	127
5.1. Dynamic grid support	127
5.2. Active power control	128
5.3. Static grid support by reactive power control	128
6. Active and reactive power controls	128
6.1. Vector control base strategies	128
6.2. Direct power control	129
7. Conclusion	129
Acknowledgments	129
References	129

* Corresponding author. Tel.: +60 16 590 3110; fax: +60 3 7967 5317.

E-mail addresses: onghc@um.edu.my, ong1983@yahoo.com (H.C. Ong).

1. Introduction

Among new ideas of extracting energy from renewable resources, photovoltaic (PV) has been becoming one of the most mature technologies in recent years. From the economical point of view, module prices are decreasing, emerging markets are increasing and investments on the manufacturing section are recovering. From the technical point of view, PV technology is developing as well. According to IHS, that efficiency of commercial module is expected to rise by 1.67% per year until 2017 [1]. As a result of the advanced technology, global PV installation is increasing unprecedentedly and is expected to exceed 40 GW by the end of 2014 as it is demonstrated in Fig. 1a. The contribution of different countries in the booming PV installation in 2014 is shown in Fig. 1b where the most significant shares belong to China, Japan, USA and Germany.

PV installation can be found in two types of stand-alone and grid connected. The former configuration might be aimed to supply local load located in a remote area far from any connection provided by the national power network [4,5], while the latter configuration, owned by individual or utility, supplies the power network. Based on size of the system, grid connected PV (GCPV) systems can be classified into three categories of utility scale, medium scale and small scale. With a capacity ranges in Megawatts, utility scale GCPV systems are normally connected to medium-voltage network via dedicated feeders. The 3-phase connections may involve several interconnected transformers. The plant itself is equipped with different means of protection (i.e. overcurrent protection, under voltage protection) as well as active anti-islanding schemes preventing power injection when the grid connection is lost. Medium scale configurations range from 10 kW to 1 MW. Smaller plants under this category, up to 100 kW, are connected to the secondary line (120/240 V) while larger plants have a connection same as utility scale GCPV systems. Finally, small scale with capacities up to 10 kW is usually installed at residence of costumers who normally own the system. Distributed small scale GCPV systems have a single phase connection to the secondary line [6].

The increasing deployment of GCPV calls for a study focusing on the big picture. It is necessary to consider not only GCPV's different types and benefits, but also rising issues in consequence of integration of this new equipment in power systems. This paper is aimed to provide a comprehensive review on the GCPV topologies and problems associated with it. Section 2 describes different possible GCPV configurations. A comparison among different configurations in terms of reliability, mismatch possibility, efficiency and expandability is also presented in this section. Section 3 discusses the cost study and different factors affecting the total expenses and return of investment of a medium or utility scale GCPV system. Negative aspects of high penetration level of GCPV

connection on quality of power and voltage such as voltage rise, voltage fluctuations and harmonic injection are investigated in Section 4. The most recent solutions proposed by the literature are studied in this section as well. Grid codes applicable to large scale GCPV systems are reviewed in Section 5. Finally, active and reactive power controls to fulfill the grid codes are investigated in Section 6.

2. Cost study

High investment demand for renewable energy harvest is one of the most important barriers against development of these technologies. To incentivize individuals and companies toward renewable energy investments, governments usually define a Feed-in Tariff which offers higher rate of purchase for the power generated from renewable sources of energy. Yet, a careful cost study is necessary to select the most economical topology and ensure expected profit. To perform the cost study leveled cost of energy (LCOE) can be investigated. Characterizing how expensive the generated energy would be, this factor can be used to assess and compare the GCPV systems economically [7]. LCOE is defined as follows [7]:

$$LCOE = \frac{TLCC}{\sum_{n=1}^N [E_n / (1+d)^n]} \quad (1)$$

where TLCC is the total cost including investment cost and maintenance cost, N is the analysis period, d is the discount rate and E_n is the energy yield in year n which can be calculated as follows:

$$E_i = E_{dc,i} \times \eta_{conv} \quad (2)$$

where η_{conv} is total converter efficiency which is multiplied efficiencies of all the power electronic converters located between PV modules and grid, and E_{dc} is the available DC energy in the period of study [8]:

$$E_{dc,i} = R_i \frac{P_{PV}}{1000} k(1 - \alpha_i N) \quad (3)$$

where R_i is the average available radiation in period i in kWh/m², P_{PV} is the rated power of the PV array in kW, k is the DC side derate factor representing efficiency reduction of power electronic component in the DC side and α_i is the degradation factor of PV modules representing efficiency reduction of PV cells [9].

Cost study helps designers to opt for the best configuration based on various factors affecting the LCOE. From the economical point of view the smallest LOCE is desired. Considering (1), TLCC and total energy yield affect LOCE directly and reversely respectively. Meanwhile, these two factors are related to other factors like maintenance cost and energy efficiency. In the next section we

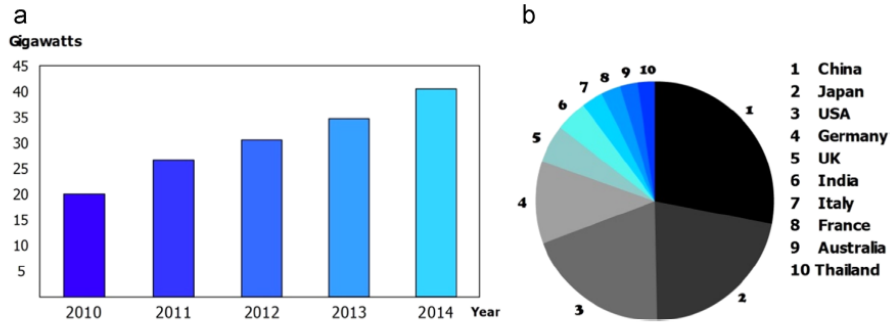

Fig. 1. (a) Global PV installation between 2010 and 2014 [2]. (b) PV installation by different countries in 2014 [3].

will get back to the cost study to evaluate different configurations but first, there are some important factors affecting the LOCE beyond the system configuration:

PV sizing ratio: owing to the effect of temperature and radiation, PV panels rarely can generate their rating power resulting in deploying a smaller interface power converter. PV size ratio is defined as the ratio between total nominal power of the PV array and inverter nominal power [10]. Correct selection of PV sizing ratio helps to save initial investment and reduce TLCC. As a result smaller LCOE can be expected [11].

Site location: Availability of solar energy plays a crucial role in making the investment profitable. Fig. 2 demonstrates the average annual mean solar irradiance in the world. The higher solar irradiance, the higher E_{dc} . The site location, thus, highly affects LOCE.

Local issues: Policies of the local authorities on renewable energy have a critical impact on the profitability of the investment. The encouraging feed-in tariff rates may incline the investments toward or against the PV technology. The size of the investment can be also affected by these policies, as the incentive rates are usually dependent on the size of power generation. The purchase rates usually decreases as the supplying power increases. Beside the government policies, price of the land where the site is located also concerns TLCC and of course LCOE [12].

3. System configuration

Designing a large scale grid connected PV system demands for careful consideration in terms of layout. Unlike small distributed PV generation system, large scale design requires huge investments. As a result, issues like cost and efficiency of the converters involved in the design are matters of concern. A smart configuration for the systems allows for maximum efficiency in different times of the year, when the available solar energy might vary due to long days of summer, short days of winter or fluctuating radiation caused by cloudy sky.

Basically, small voltage and current output of PV modules in comparison with grid requirement is the reason for series and parallel connections of PV modules. Series connection of the modules, string, provides a suitable voltage range to be inverted while parallel connection of strings is used to supply a higher current. Meanwhile, the number and position of converters in a PV system of parallel connected strings creates different layout possibilities to be studied. Numerous configurations of GCPV systems proposed by the literature can be classified into four categories of Fig. 3. In a centralized configuration, Fig. 3a, a combination of series and parallel connections of PV modules supplies power to a line commutated inverter. The centralized configuration represents an old technology suffering from several severe problems such as high harmonic injection [14]. Fig. 3b demonstrates "string" topology in which each string supplies the grid through an inverter. The next configuration called "Multi-string" is illustrated in Fig. 3c. In this system, each string is equipped with a DC-DC converter which performs the maximum power point tracking (MPPT) operation. The strings then share their power through a DC-link with an inverter which controls the voltage of the DC link by transferring extra power to the grid. A more reliable and efficient system can be achieved by using several low power parallel inverters rather than one centralized one [15]. The last configuration to be discussed is AC-module which is shown in Fig. 3d, where a complex power electronic interface is used for each module. Having several advantages like expandability and easy installation by non-specialized individuals, AC-module suggests the privileged topology for small scale distributed generation (DG) systems. However, the high required voltage boosting leads to fluctuation of DC power and reduced efficiency of MPPT as a result [16,17]. This can only be fixed by using large-capacity input capacitor which puts a dent in the efficiency and lifetime of the inverter [18-20]. Complex topology and small power rating limit the usage of this structure for medium and utility scale GCPV systems [15].

To compare these topologies there are different factors to be considered:

Energy efficiency: Total efficiency of the system is multiplied efficiency of PV module, MPPT and converter. Relationship between power and efficiency of typical inverters is illustrated in Fig. 4. Small drop in the efficiency can be observed for the

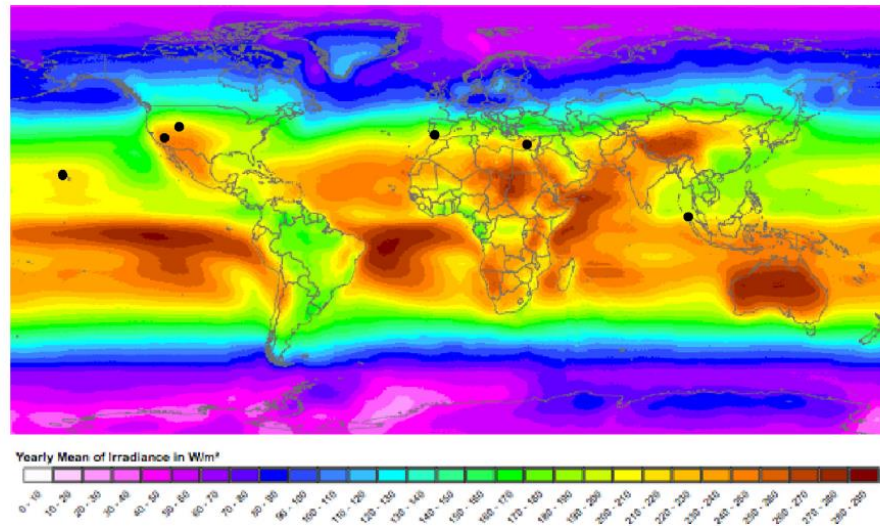

Fig. 2. Yearly mean of irradiance in the world [13].

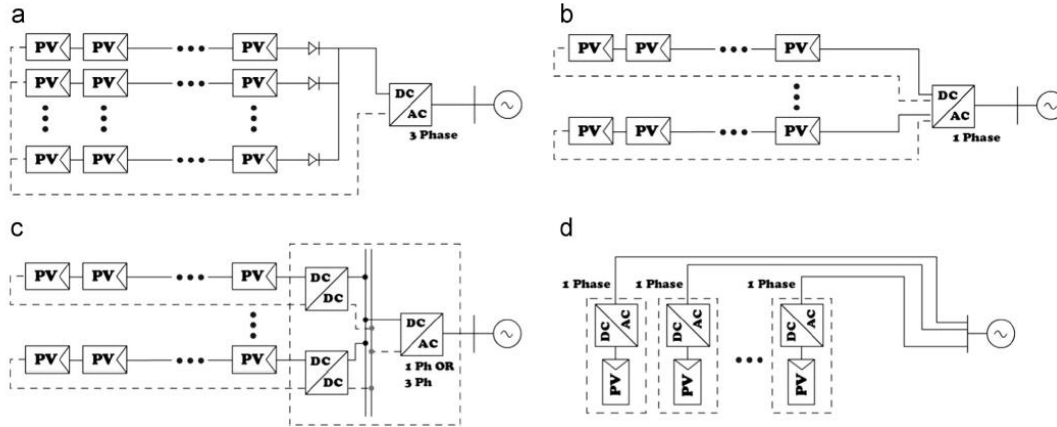

Fig. 3. Different topologies for a grid-connected PV system. (a) Centralized approach. (b) String approach. (c) Multi-String approach. (d) AC-module approach.

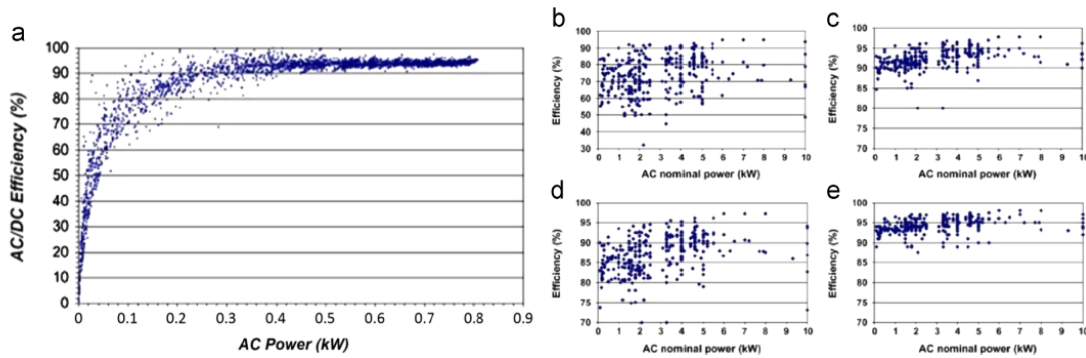

Fig. 4. (a) Efficiency-power characteristic of generic grid-connected inverters, (b) efficiency vs AC nominal power (kW) for inverters under experiment with 5% of AC nominal power, (c) efficiency vs AC nominal power (kW) for inverters under experiment with 10% of AC nominal power, (d) efficiency vs AC nominal power (kW) for inverters under experiment with 20% of AC nominal power, and (e) efficiency vs AC nominal power (kW) for inverters under experiment with 60% of AC nominal power [25].

power ranges between 10% and 30% while operation in less than 10% of nominal power cause the efficiency to fall substantially. Consequently centralized inverter structures imply lower efficiency as the inverter is not operated in its rated power when the solar radiation is low. In contrast, maximum efficiency can be achieved through the multi-inverter structure of [15], in which a number of parallel inverters shuts down letting the rest work at their rated power. According to [8], the more efficient operation in a multi-string structure is achievable through increasing the number of parallel inverters. The cost of such a system, however, is likely to rise substantially [21]. Owing to a complex structure, AC-module topology has lower efficiency comparing to the other topologies [15].

Reliability: As the size of a grid-connected system increases, the reliability becomes more of a critical issue. Unlike a small DG system, a utility scale GCPV system is responsible for supplying a part of power demand during daytime. Different topologies of Fig. 3 imply different reliabilities. In a PV system with a centralized inverter, a switch failure may cause the whole unit to shut down while the same problem in string topology causes only a part of power to be lost [8]. Multi-string topology faces the same problem unless the parallel inverter structure is used. The best reliability belongs to AC-module topology since each module supply its power independently

although, as was mentioned earlier, this configuration is not suitable for large scale systems.

Mismatch: When the solar radiation receiving by the series connected cells in a string is different, a number of PV cells are bypassed by bypass diodes of the module for protection reasons. Power mismatch caused by shadow not only reduces the generated power, but also affects the correct operation of MPPT algorithm by creation of a multi-peak power-voltage curve leading to reduction of MPPT efficiency [22–24]. Generally, as the number of series connected PV module increases, the possibility of power mismatch increases as well. As a result, owing to the need of long strings of series connected modules, centralized and string topologies are likely to face the mismatch problem. Due to the use of a DC boost level in multi-string topology, number of series connected module and as result the mismatch possibility is lower in this configuration. The lowest mismatch possibility is achieved by AC-module structure due to the use of exclusive power electronic converter for each PV module.

Expandability: For a GCPV system, the capability of the system to be expanded in the future is very important. Typically, the cost is the basic barrier against expandability. In a centralized topology for example, expanding the system requires changing the inverter due to its limited rating power. In case of string

topology, enlarging the system imposes high cost of adding another string which needs at least 16 modules or a transformer [14]. The cost of expanding a multi-string topology is also high as it requires new string and DC converter. In contrast, AC module topology can be easily expanded by connecting another module to the system.

Cost: it is one of the most important factors to be considered. There is, however, a fundamental difference between the cost and other factors as they impose a requirement to be achieved and cost is to be minimized. As a result when there is more than one candidate solution, it is cost that determines which solution must be applied. In order to evaluate different topologies from the economical point of view, LOCE can be used. For instance according to (1), the lower the initial and maintenance cost, the more economical design could be achieved. Furthermore, factors like efficiency, DC side derate factor and PV degradation factor concern total energy harvest and ultimately LOCE. T , using high quality PV module and well-designed interface converter can also help us to minimize LOCE. Among different topologies of GCPV system, centralized configuration suggests the lowest initial investment [15]. However lower reliability and energy efficiency of this topology imply lower energy harvest in the period of study which ultimately increases the LCOE. Between string and multi-string approaches, the former demands for lower budget as there is no extra DC-DC converter in the system. Finally the most expensive configuration is AC-module as each PV module is equipped with a converter; however the unique compact structure of this topology sometimes makes it the only feasible solution for small scale DG systems [14].

In conclusion, having problems like high mismatch possibility, low reliability and limited expandability, centralized configuration suggests the weakest strategy. However, the use of one converter for the whole system makes centralized strategy less expensive comparing to string and multi-string strategies. For a small scale GCPV system, the best configuration is AC-module topology as the system can be easily installed and expanded. Furthermore, mismatch is not a problem in this topology. For medium and utility scale GCPV system, the most efficient and reliable configuration is suggested by multi-string inverter.

4. Voltage and power qualities

Despite the advantages of PV systems, high penetration level of GCPV causes new problems in the operation of power system. Solar energy is extremely intermittent and available only during daytimes. The output power fluctuates due to irradiance variation caused by passing clouds. More importantly, owing to the deployment of small scale distributed PV systems rather than a centralized system, the controllability over generating power is limited. Voltage rise, voltage fluctuation, voltage unbalance and harmonics are major problems created by GCPV systems, especially small scale rooftop configurations connected to LV distribution network.

4.1. Voltage rise

When the number of GCPV systems connected to a feeder is high, generated power of the PV systems might offset the load demand of the feeder. Reverse power flow happens when the extra generated power flows through the feeder transformer to grid creating several protection problem as well as voltage rise which is illustrated in Fig. 5. When the PV generated power is lower than the power demand, small drop is observed across the feeder. If the generated power equates the load demand, power

transferred through the transformer is zero and voltage across the feeder remains constant. When the generated power exceeds load demand a voltage rise is observed across the feeder. Due to the risk of damage to the equipment connected to feeder caused by voltage rise, standards impose limits for voltage variation. For example admissible voltage variation for VDE 0126-1-1 is between 85% and 110% of the standard rated voltage. 35% Voltage rise is allowed by IEC61727 provided this condition does not last longer than 2 s [26]. To overcome the overvoltage problem three strategies are proposed by the literature: Active power curtailment, reactive power control and energy storage installation.

4.1.1. Active power curtailment

Due to highly resistive line characteristics, in a LV network the impact of active power on voltage is more than reactive power [27]. As its name suggests, active power curtailment (APC) strategy avoid the overvoltage by limiting power being extracted from the PV. As a result the output power of the inverter is [28]

$$P_{inv} = P_{MPP} - f(V) \quad (4)$$

where P_{inv} is the output power of the inverter, P_{MPP} is the maximum power point of the PV and $f(V)$ is a conditional function that limit the inverter output power with respect to voltage.

By controlling $f(V)$ this method limits generated power not to exceed the load demand of feeder. As a result reverse power flow is avoided. Despite the effectiveness, APC limit the revenue of the owners so from the economical point of view it is not an attractive solution.

4.1.2. Reactive power control

Overvoltage mitigation can be achieved through reactive power absorption of inverter. As it is illustrated in Fig. 6, when the current is in phase with voltage (blue color), overvoltage occurs owing to impedance of the feeder. However, the voltage on the second bus can be significantly reduced by a leading current (red color). The inverter, thus, has to absorb reactive power to serve this purpose. Reactive power control can be achieved through either a centralized or local approach [29]. In a centralized approach, communication between inverters and a center, under supervision of utility, provides optimal reactive power management to reduce voltage bus of the feeder to a safe level [30]. Centralized approaches demand for development of sensors, communication and control systems of the typical inverters that needs big investments [29]. In contrast, local reactive power control strategies are independently implemented on the inverters connected to the feeder. Standard local approaches can be classified as fixed Q , fixed

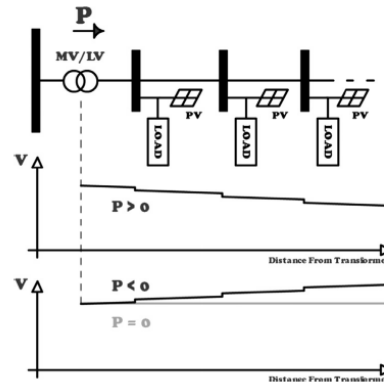

Fig. 5. Creation of voltage rise on a feeder.

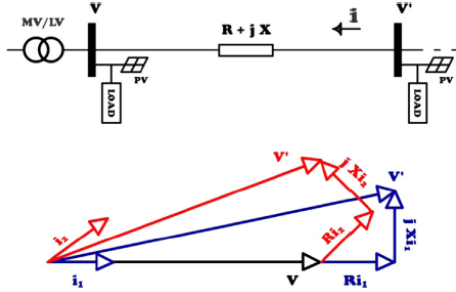

Fig. 6. Over voltage mitigation with reactive power control. (For interpretation of the references to color in this figure legend, the reader is referred to the web version of this article.)

$\cos(\varphi)$, variable $\cos(\varphi)$ and $Q(U)$ methods [26,31,32]. The fixed Q and fixed $\cos(\varphi)$ methods are perhaps the simplest strategies to implement. To ensure the overvoltage is controlled, these methods suggest either a fixed amount or a fixed proportion of reactive power over active power to be supplied by the inverter. However, in case of low active power generation, where the reverse power flow no longer occurs, reactive power absorption only leads to voltage drop and extra losses. To avoid such problems variable $\cos(\varphi)$ and $Q(U)$ methods propose adaptable approaches. The former define the proportion Q/P with respect to the generated power. Consequently, when the generated power is low absorbing reactive power decreases. Finally, the $Q(U)$ method defines the absorbing reactive power as a function of voltage. The inverter, therefore, absorbs reactive power in case the voltage exceeds a certain limit.

The absorbed reactive power by the inverter has to be supplied by utility transformers limiting the capacity and efficiency of the transformers. In addition, higher currents must be conducted through the low-voltage (LV) transmission lines implying higher copper loss [28]. Owing to these disadvantages, some countries restrain any reactive power control in LV networks [33].

4.1.3. Energy storage system

In this strategy, all the GCPV systems connected to LV feeders have to be associated with an energy storage system (ESS). During midday, EES temporarily stores the excessive active power which is then injected to the grid at night [34–36]. In this strategy, charging rate of the energy storage is important. A large value for the rate causes the EES becomes fully charge early and unable to accept the excessive power during peak generation period (usually noon time). In contrast, a small rate might be insufficient to avoid reverse power flow. In a profound approach [34], proposes a variable charging rate strategy. In this approach, the charging rate follows the same trend as daily generated power. The rate starts with a small value at early morning and increase gradually until noon time, where the generated power reaches its peak value. A downward trend is then considered for the charging rate to store the rest of surplus generated power.

4.2. Voltage fluctuations and unbalance

The intermittency of the solar energy leads to voltage fluctuation. Voltage variation is normally controlled by operation of on-load tap-changers (OLTC) and voltage regulators (VL). However, these devices are slow and usually designed based on assumption that power flows in one direction only [37]. Voltage fluctuations caused by high penetrated GCPV in the LV network lead to frequent operation of OLTC and VL shortening their life time [6].

In addition, the impact on lighting load might be observed as flicker. According to IEEE Std 1547-2003 4.3.2 DG systems shall not create objectionable flicker for other customer on the area electric power who might use different lighting systems including incandescent and fluorescent [38].

Moreover, growing installation of GCPV in LV network leads to voltage unbalance problem. This is because these DG systems, driven by individual owners, are not centrally planned and three phases of distribution transformer are likely to be loaded differently. To evaluate this issue, voltage unbalance factor is defined as follows:

$$VUF\% = \frac{V^-}{V^+} \times 100 \quad (5)$$

where V^- is the negative sequence voltage and V^+ is the positive sequence voltage.

For medium or utility scales configuration having a 3 phase connection to the grid, several strategies have been proposed to mitigate voltage variation and voltage unbalance. Special control strategies can be implemented on the inverter to suppress the voltage variation [39,40]. Based on voltage vector at the inverter terminals and reference vector an error is created. The error is then fed to a controller to modify the reference voltage instantaneously causing to suppress voltage fluctuation and unbalance. In [39] a combination of sliding mode control, predictive control and variable structure control is used. Resulted structure is robust and effective; however the high degree of complexity and high computational burden that entails are the major obstacle against this kind of strategies.

Distributed static synchronous VAR compensators (DSTATCOMs) can be installed in parallel with the GCPV system. Transferring reactive power to grid, these devices are able to mitigate voltage unbalance and suppress voltage variation [41]. Active filters might also be used to regulate voltage and damp its fluctuation [42]. In this case harmonics attenuation can also be achieved.

Despite the effectiveness, these devices are expensive. In addition, as it is shown in Fig. 7, they should be installed on the same bus as GCPV which make it less of a practical solution for small scale DG systems connected to LV network.

4.3. Harmonics

Current harmonics are sever if line commutated inverter is used. However owing to non-ideal effects which are usually neglected, even self-commutated inverters might contribute to harmonic injection [43]. On the other hand, to comply with the standards harmonic injection has to be controlled. For instance, Table 1 demonstrates the maximum allowed harmonic injection by IEEE Std 1547-2003 4.3.3 and the corresponding literature was able to achieve this requirements. Dead time considered for the switches of the same leg of the inverter, distorted magnetization current of transformers and voltage drop on the switches are factors that introduces odd harmonics to the grid [43]. Even harmonics may also be created as a result of DC injection by GCPV system. As it is illustrated in Fig. 8, DC injection is originated from

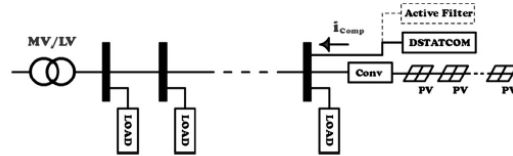

Fig. 7. DSTATCOM and active filter connection for voltage variation and unbalance compensation.

Table 1
Maximum harmonic current distortion in percent of current. Even harmonics are limited to 25% of the Odd harmonic limit shown [38].

Individual harmonic order (Odd harmonics)	$h < 11$	$11 \leq h < 17$	$17 \leq h < 23$	$23 \leq h < 35$	$35 \leq h$	Total demand distortion
Percent (%)	4.0	2.0	1.5	0.6	0.3	5.0
[46]	-	-	Satisfied	Satisfied	Satisfied	Satisfied
[43,47,49]	Satisfied	Satisfied	Satisfied	Satisfied	Satisfied	Satisfied

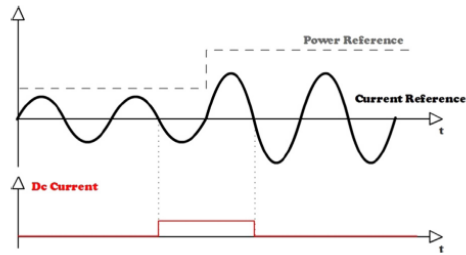

Fig. 8. DC current injection PV as a result of fast MPPT.

a change in active power being transferred to the grid. According to IEEE Std 1547-2003 4.3.1 DC injection by DG systems shall not exceed 0.5% of rated current [38].

4.3.1. Passive filters

To mitigate the harmonic injection, passive and active strategies might be used. Passive strategies suggest blocking the flow of harmonics to the grid by means of passive filters. Passive filters comprise series and parallel connections of passive elements (i.e. inductor and capacitor) that allow only the fundamental current to pass. These filters are widely used for high order harmonic attenuation. In fact no inverter is connected to the grid without a passive. A third order LCL filter is an attractive choice for DG systems due to its advantages such as small inductor and high attenuation of harmonics [44]. However owing to undesired resonance in certain frequencies, LCL filters might create stability problems which can be solved by active damping methods [45]. Overall, passive filters are effective for high order harmonic mitigation although they can scarcely be designed to block low order harmonics without considerable attenuation in fundamental frequency.

4.3.2. Active strategies

Active strategies can be classified into two categories of active filters and active damping methods. Active filters are extensively investigated by the literature [46-48]. In a series, shunt or hybrid configuration, active filters generate a compensating current to be added to the PV supplying current. The compensating current suppresses unwanted current harmonics being injected to the grid. Despite good performance, active filters need dedicated inverter and DC power supply which make this strategy too expensive for small scale GCPV systems.

Active damping methods probably suggest the most economical way to reduce the harmonics. In these techniques harmonics are first detected in the sensed output current of the inverter. This is then used to generate a counter voltage to be added to reference voltage of the inverter and suppress the selected harmonics. As a result there is no need to install any extra passive or active filter and compensation can be achieved through an elaborated control

strategy such as adaptive filter based control [43,49] and repetitive controller-based harmonic elimination [50].

5. Grid codes

Grid codes are a set of requirements to be met by all the facilities connected to grid ensuring stable and economic operation of power network. For the generating units, grid codes mostly concern active and reactive power supports during and after faults. When a fault takes place in a region, equipment connected in the vicinity experience a voltage drop with a severity depending on the distance to fault. In addition, in case of asymmetrical fault, voltage unbalance might be experienced as well. To overcome these problems and avoid instability of the power system, generating units must stay connected during the fault and support the voltage by injecting reactive power. This practice is referred to as fault-ride-through (FRT). Active power control is also necessary to support abnormal frequency condition. On the other hand, high penetration of GCPV necessitates contribution of these facilities to the grid stability. For this matter, countries such as Spain and Germany, who expect large share of PV power generation in their power system, established grid codes for GCPV systems connected to low and medium voltage distribution system [51,52]. These requirements include dynamic power supports, active power control and static grid support by reactive power control.

5.1. Dynamic grid support

Dynamic grid support requires that the power generation unit stay connected during and after the fault and support voltage by reactive power injection. Fig. 9 illustrates the limiting curve of non-synchronous generator power plants (e.g. GCPV system) during fault. Unit must stay connected during a voltage drop down to zero with a duration of $t \leq 150$ ms. After this duration the unit is required to stay connected if the voltage is above the borderline 1. In case the voltage is located in the zone between borderline 1 and borderline 2, the unit is also expected to be ridden through with the following options available based on agreement with the network operator:

- Feed-in of a short-circuit current
- Moving the borderline 2 depending with respect to the concept of grid connection
- Disconnection up to 2 s

In the zone between the border line 2 and blue line, longer disconnection is possible. Finally for the zone below the blue line there is no requirement imposed to the unit to remain connected.

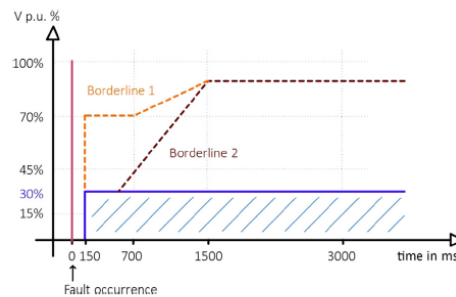

Fig. 9. Limiting curves of voltage for a PV power plant in case of fault occurrence. (For interpretation of the references to color in this figure legend, the reader is referred to the web version of this article.)

Link to Full-Text Articles :

<http://www.sciencedirect.com/science/article/pii/S1364032115003342>

<http://ac.els-cdn.com/S1364032115003342/1-s2.0-S1364032115003342-main.pdf? tid=83672e64-4010-11e5-8c50-00000aab0f27&acdnat=1439287717 a061c21f1e8b808d63f7f73976f789cb>