

### T13-O-15: Air conditioning components

## **THE USE OF HEAT RECOVERY DEVICES FOR REDUCING ENERGY CONSUMPTION OF TREATING VENTILATION AIR IN A TROPICAL OPERATING THEATRE**

Y.H. Yau\* and C.B. Lim

Department of Mechanical Engineering, University of Malaya, 50603 Kuala Lumpur, Malaysia

\*Corresponding email: yhyau@um.edu.my

**Keywords:** Heat recovery wheel, Heat pipe heat exchanger, Energy savings, Tropical operating theatre, HVAC simulation

### **SUMMARY**

In the operating theatre, where exhausted air is not permitted to be re-circulated, maintaining the conditions could be tedious on the HVAC systems and found to be energy inefficient. This research will look into the potential energy savings using heat recovery devices in treating the ventilation air, without compromising the occupants' thermal comfort and health in the conditioned space. For the purpose of this research, Operating Theatre 1 of a private hospital in Malaysia was used for analysis and simulation. The existing air conditioning system was modeled in TRNSYS as the baseline model and verified using measured data obtained from the fieldwork. Two heat recovery devices were used in the two- redesign systems and simulated in TRNSYS to analyse the energy saving potential of these devices. The results indicated that the heat recovery wheel could reduce the annual operating cost by 31% while the heat pipe heat exchanger by 28%.

### **NOMENCLATURE**

AHU	Air Handler Unit(s)
ASHRAE	American Society of Heating, Refrigerating and Air-Conditioning Engineers
CWC	Chilled Water Coil
DBT	Dry-Bulb Temperature
HPHX	U-shape heat pipe heat exchanger
HVAC	heating, ventilating and air conditioning
OT	operating theatre
OT1	operating theatre 1
RH	relative humidity
TMY	Typical Meteorological Year
TRNSYS	transient systems simulation program
WBT	Wet-Bulb Temperature

### **INTRODUCTION**

The most demanding independent indoor zones in a hospital are operating theatres (OT) and their interconnecting hallways and ancillary work areas. The indoor environmental quality in OT affects the working conditions, safety and health of the medical personnel who work in

these environments. Heating, ventilating and air conditioning (HVAC) installations control indoor air quality and aseptic conditions, and secure healthy, safe and suitable indoor thermal (i.e. temperature, humidity, air quality and airflow) conditions for surgeons and medical staff, and of course the patients (Balaras et. al., 2006). Strict indoor environmental standard of operating theaters will translate into high cost in HVAC equipment installation, operation and maintenance, which demands efficient design and operation to ensure economical energy management. Energy saving strategies can be employed for the purpose of energy conservation, without sacrificing comfort, and overall indoor environmental quality. Therefore, the use of a heat recovery device such as heat pipe heat exchanger (HPHX) and heat wheel for reducing the energy consumption of treating ventilation air in an OT can be a practical alternative.

A literature search has been carried out on research work of HPHX and heat recovery wheel applied in HVAC systems in the tropics, and it revealed that complete research on energy savings using HPHX and heat recovery wheel are very limited in the tropics (Yau, 2008), especially in the hospitals. Therefore, this investigation is required to be carried out and the major aim is to examine the year-round impact on energy consumption in an OT for a private hospital located in a tropical area to be predicted realistically as a possible justification for retrofitting either the heat recovery wheel or the HPHX into the space's conditioning system.

## **TRNSYS OVERVIEW**

TRNSYS is transient systems simulation software with a modular structure (Klein et. al., 2004) and is applied in the present research for modeling the HVAC system and the building in which it operates. The modular nature of TRNSYS has allowed empirical representations of all non-standard components to be added into the TRNSYS programme. For this reason, the performance characteristic curves for Carrier AHU 39G-0612 have been obtained from Carrier Malaysia Pte. Ltd. (Chea, 2008) and used in the present simulation. Also, the Bry-Air heat recovery wheel performance characteristics were obtained from Bry-Air Malaysia Pte. Ltd. (Lim, 2008) while an empirical HPHX was developed using performance specifications generated from SPC HPD v2.1 software downloaded from manufacturer's website (S&P Coil Product Limited, 2008).

Three different HVAC plant configurations are the subjects of these simulation, labeled as Plant A, Plant B and Plant C. Plant A is the existing system for the OT, Plant B is a heat recovery wheel system, while Plant C is a HPHX system. In each case, the appropriate TRNSYS circuit has been assembled using IISIBAT 3.0 software, and the arrows in the TRNSYS circuit indicating the airflow direction. Figure 1 shows the typical TRNSYS circuit for Plant A. Note that the details of TRNSYS circuit for Plants B and C could be found in reference (Lim, 2008). Figures 2, 3 and 4 represent the schematic diagrams of Plants A, B and C respectively.

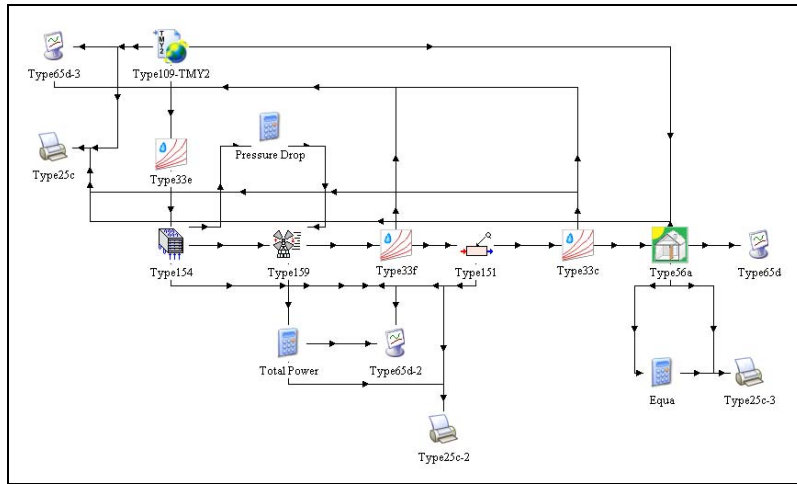

Figure 1 The typical TRNSYS circuit for Plant A

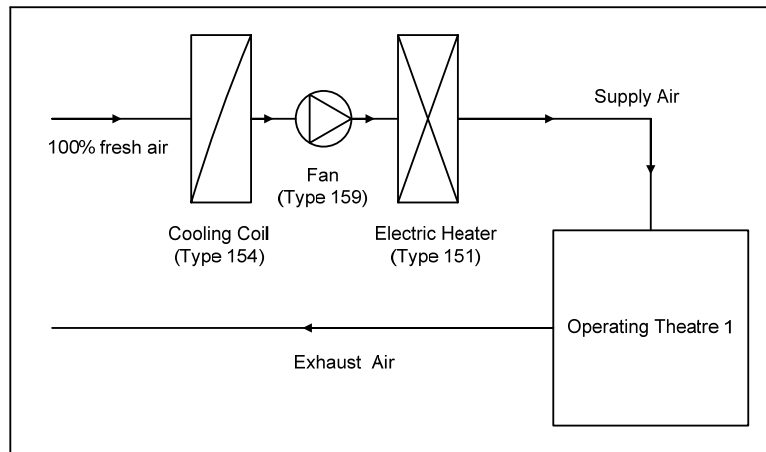

Figure 2 The schematic diagram of Plant A

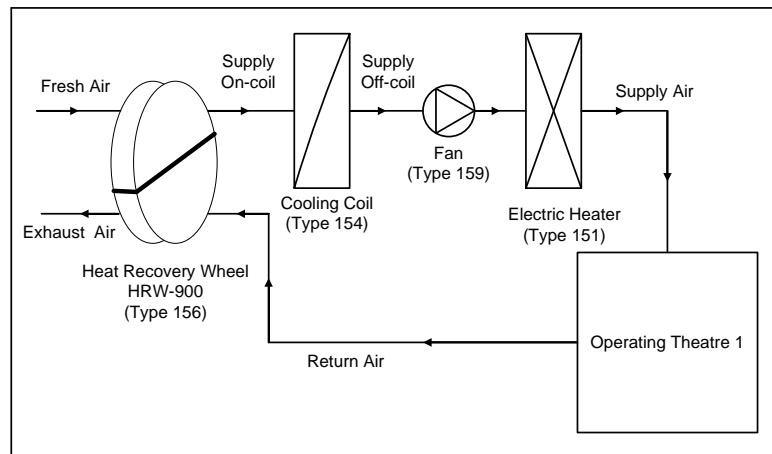

Figure 3 The schematic diagram of Plant B

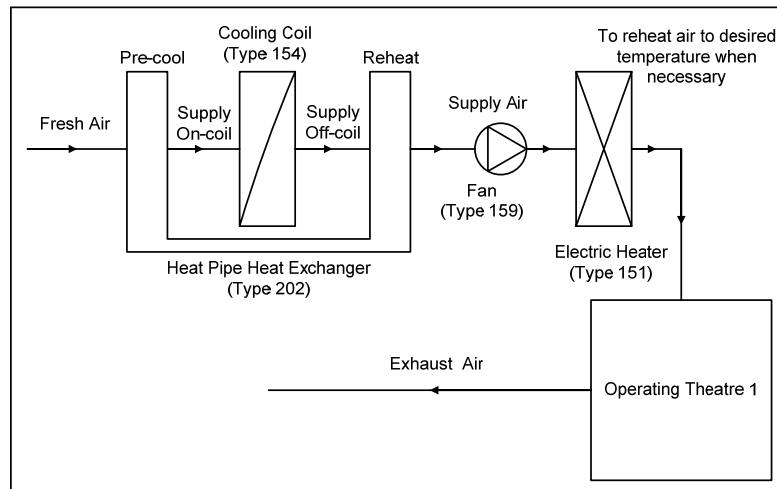

Figure 4 The schematic diagram of Plant C

## FIELDWORK STUDY

During the fieldwork study, the indoor air conditions such as dry bulb temperature (DBT), wet bulb temperature (WBT), air velocity, concentration of carbon dioxide ( $\text{CO}_2$ ) and relative humidity (RH) were acquired. Before conducting the measurement, the OT to be examined was given an approximately one hour time for the indoor conditions to achieve its required room conditions in steady state with all openings closed. The KANOMAX Indoor Air Quality Monitor was used to record data in the OT. The average DBT of the room is found to be  $19.5^\circ\text{C}$ , with RH of 58 % and absolute humidity of  $0.009757 \text{ g/m}^3$ .

## SIMULATION PROCEDURES

For the purpose of this research, the existing system (Plant A) was simulated and verified using the data collected during the fieldwork study. Three non-standard TRNSYS types have been created using TRNSYS Simulation Studio for Plant A simulation which are an empirical cooling coil module (Type154) created according to manufacturer's data, an electric heater (Type151) with a rated capacity of 4.5 kW, and an empirical fan (Type159) created using Carrier selection software to account for the corresponding fan power consumption due to air pressure drop in the HVAC system so as to maintain a consistent air flow rate. The verified simulation of Plant A was then used to redesign the existing system to build Plant B and Plant C.

### Developing Empirical Chilled Water Coil

The existing HVAC system in the Operating Theatre 1 (OT1) is supported by Carrier 39G-0612. In order to simulate the HVAC system in the TRNSYS Simulation Studio as close as possible to the actual conditions, it is essential to develop an empirical chilled water coil (CWC) instead of using built-in module available in TRNSYS. The CWC performance curves were obtained from Carrier International just mentioned. The chilled water flow rates are in the ranges of 0.2 L/s to 5.5.

To compute the performance of the CWC empirically, the following graphs were generated and the corresponding equations were used to form the FORTRAN source code for the empirical CWC: Entering DBT VS Leaving DBT, Entering WBT VS Leaving WBT, Air

Pressure Drop VS Entering DBT, Sensible Cooling Load VS Entering DBT, and Total Cooling Load VS Entering DBT.

For a given chilled water flow rate, there are ten sets of equations (corresponding to ten different RH conditions) for each of the graphs above, which gives a total of 50 equations per chilled water flow rate. The completion of the entire empirical CWC requires a total of 850 equations to form the complete FORTRAN source code.

### Developing Fan Performance Curve for AHU39G-0612

The fan performance curve was manually generated using Carrier Electronic Catalog AHU Selection Software Version 3.12. The fan used in the air handling unit (AHU) is of forward-curved type with horizontal discharge. At a fixed air flow rate of 1400 L/s (actual flow rate is 1246 L/s), the graph Fan Power (kW) against Total Static Pressure (Pa) can be obtained in reference (Lim D.C.B, 2008) and the resulting equation was built and written in FORTRAN source code for the fan (Type159) in the simulation. The calculation of Total Static Pressure (TSP) takes into account of the Cooling Coil Static Pressure (CSP), Total Accessories Static Pressure (TASP), and External Static Pressure (ESP) as shown below:

$$\text{TSP} = \text{CSP} + \text{TASP} + \text{ESP} \quad (1)$$

Cooling Coil Static Pressure (CSP) is taken as Air Pressure Drop (APD), therefore,

$$\text{TSP} = \text{APD} + \text{TASP} + \text{ESP} \quad (2)$$

### Developing Empirical Heat Recovery Wheel

The non-standard component, Bry-Air Heat Recovery Wheel Model HRW-900 has been modeled based on actual model from Bry-Air (Malaysia)(Lim P.H., 2008). It is important to mention that the performance data and specification for the product has been obtained from Bry-Air, (Lim P.H., 2008) and the equations involved were compiled in FORTRAN. The details of the performance data and specification for the heat recovery wheel could be obtained from reference (Lim D.C.B, 2008). With the known performance specification for the heat recovery wheel,

Let

$\varepsilon$	:	Supply Side Sensible and Latent Recovery Efficiency
$T_n$	:	Incoming air temperature, taken from TMY2 Weather Data
$W_o$	:	Incoming air humidity ratio, taken from TMY2 Weather Data
$T_r$	:	Return air temperature, which is from room indoor condition
$W_r$	:	Return air humidity ratio, which is from room indoor condition
$T_s$	:	Supply air temperature to cooling coil
$W_s$	:	Supply air humidity ratio to cooling coil

Hence, Recovered temperature,

$$\Delta T = \varepsilon (T_o - T_r) \quad (3)$$

Recovered moisture,

$$\Delta W = \varepsilon (W_o - W_r) \quad (4)$$

$$\therefore T_o - \Delta T = T_o - \varepsilon (T_o - T_r) \quad (5)$$

$$W_o = W_o - \Delta W = W_o - \varepsilon (W_o - W_r) \quad (6)$$

$$\text{Sensible load recovery} = \text{air flow} \times \text{air density} \times 1.012 \times \Delta T \quad (7)$$

$$\text{Latent load recovery} = \text{air flow} \times \text{air density} \times 2454 \times \Delta W \quad (8)$$

$$\text{Power to operate this heat wheel} = 0.186425 \text{ kW} \quad (9)$$

The equations obtained were used to build the empirical model for the heat recovery wheel and used in Simulation Studio to generate the indoor conditions for OT1 and the corresponding energy consumption.

### Developing Empirical Heat Pipe Heat Exchanger

For the purpose of this study, an empirical HPHX was developed using performance specifications generated from SPC HPD v2.1 software downloaded from manufacturer's website (S&P Coil Product Limited, 2008). The performance specifications for the empirical HPHX are as shown below:

Air Flow	:	1246 L/s
Sensible Recovery Efficiency	:	25.4 %
Pressure Drop	:	493 Pa

With the known performance specifications for the HPHX,

Let

$\varepsilon$	:	Sensible Recovery Efficiency
$T_{fresh}$	:	Incoming fresh air temperature
$T_{offcoil}$	:	Off-coil temperature
$T_{oncoil}$	:	On-coil temperature
$T_{supply}$	:	Supply air temperature after HPHX

Hence,

$$\text{Recovered temperature, } \Delta T = \varepsilon (T_{fresh} - T_{offcoil}) \quad (10)$$

$$\therefore T_{oncoil} = T_{fresh} - \Delta T = T_{fresh} - \varepsilon (T_{fresh} - T_{offcoil}) \quad (11)$$

$$\therefore T_{supply} = T_{offcoil} + \Delta T = T_{offcoil} + \varepsilon (T_{fresh} - T_{offcoil}) \quad (12)$$

$$\text{Sensible load recovery} = \text{air flow} \times \text{air density} \times 1.012 \times \Delta T \quad (13)$$

The equations obtained were used to build the empirical model for the HPHX and used in the Simulation Studio to generate the room conditions for OT1 and the corresponding energy usage.

### SIMULATION RESULTS AND DISCUSSION

Plant A was used to simulate the yearly performance for a period of 8760 hours simulation with hourly time step. The simulated result is as shown in Table 1. It is evident that for the indoor conditions of OT1, the room DBT is in the range of 19.0°C and 24.0°C while the RH in the room is in between 56% and 65%. The average room DBT and RH throughout the year are 21.0°C and 59% respectively. Average absolute humidity in the room is found to be 0.009298 kg of moisture per cubic meter of air. The measured average DBT of the operating theatre during site work in OT1 at the hospital was found to be at 19.5°C, with an average RH of 58%, while the measured average absolute humidity is recorded as 0.009757 kg of moisture per cubic meter of air. From the results shown in Table 1, it is known that the variation of the simulation results and the measured data are less than 10%, which suggests that Plant A can be verified and is acceptable for further analysis. Note that the slight variation might be attributed to sensitivity of measuring devices, difference between the actual performance of the cooling coil and the empirical cooling coil module, and difference between the actual load conditions in the space and the simulated load conditions.

Table 1 The room conditions of Operating Theatre 1 for Plants A, B and C

Plant	Average DBT (°C)	Average RH (%)	Variation (%)	
			DBT	RH
<b>A (Baseline Model)</b>	21.25	58.99	Not Applicable	Not Applicable
<b>B (Heat Recovery Wheel)</b>	21.09	58.43	0.75	0.95
<b>C (HPHX)</b>	21.24	58.06	0.05	1.58

For the purpose of comparison, it is desired that all HVAC systems be compared based on the same ground of which in this case, the room conditions are the desired simulated conditions. All HVAC systems will be evaluated based on their energy consumption and annual operating cost in achieving the same room conditions. The simulated results for Plant B are shown in Table 1. It is clear that the average DBT and RH throughout the year are 21.1°C and 58% respectively, of which is acceptable for comparison with the baseline simulation model since the variation is less than 1%.

The typical simulated room condition results for Plant C are shown in Figure 5. The average room DBT and RH throughout the year are 21.2°C and 58 % respectively, of which is acceptable for comparison with the baseline simulation model since the variation is just 0.01°C (0.05%) for DBT and 1.58% variation for room RH.

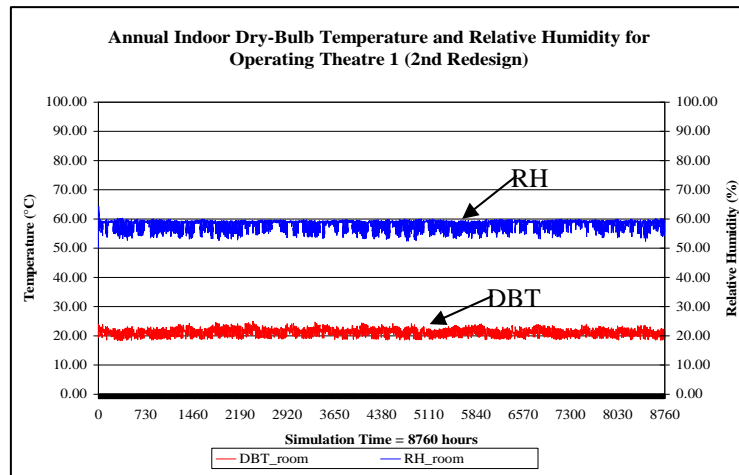

Figure 5 The typical simulated room condition results for Plant C

## ENERGY CONSUMPTION ANALYSIS

It is pertinent to mention that for the purpose of this research, a chiller with a specific rated capacity running at a full load condition at all times will be assumed to support the HVAC system in order to compute the energy consumption corresponding to the total cooling coil load at any given time. The Carrier Screw Compressor Water-Cooled Liquid Chiller Model 30GHXC-200 with a net nominal cooling capacity of 707 kW and nominal power input of 154 kW was used to compute the power consumption by the cooling coil. The chiller has a rated capacity of 0.2178, which means the chiller takes 0.2178 kW of power for every kilowatt of cooling load in the CWC. The total energy consumption only considers the power consumed by AHU fan, electric heater and the chiller.

### Plant A

It can be observed from Table 2 that the total annual energy consumption for the air conditioning system in the operating theatre is 170770.99 kWh, which is an amount of USD 11,100 annually spent on keeping the desired indoor conditions of the operating theatre based on the tariff rates for commercial applications of USD0.065/kWh (National Energy Board, 2008).

Table 1 Comparison of Energy Consumption and Operating Costs for Plants A, B and C

	Plant A	Plant B	Plant C
<b>Total Cooling Coil Load (kJ/year)</b>	1703198914.17	753281013.51	1432939527.81
<b>Total energy consumed by heat wheel (kJ/year)</b>	-	5879098.81	-
<b>Total energy consumed by heater (kJ/year)</b>	141912000.00	141912000.00	-
<b>Total energy consumed by AHU fan (kJ/year)</b>	101906844.81	112581164.70	132185277.63
<b>Total energy consumed by chiller (kJ/year)</b>	370956723.51	164064604.74	312094229.16



<b>Total energy consumed (kJ/year)</b>	614775568.32	424436868.25	444279506.78
<b>Total energy consumed (kWh/year)</b>	170770.99	117899.13	123410.97
<b>Tariff rates from TNB (USD/kWh)</b>	0.065	0.065	0.065
<b>Annual operating cost (USD/year)</b>	USD11,100	USD7,663	USD8,022
<b>SAVINGS (USD/year)</b>	Not Applicable	USD3,437	USD3,078

### Plant B

It is clear that from Table 2, the annual total energy consumption for Plant B is 117899 kWh, which is an amount of USD7,663 annually spent on keeping the desired room conditions of OT1.

It can be noticed that the total cooling coil load shows a remarkable decrease as compared to the previous coil load in Plant A from 1703.20 GJ/year to 753.28 GJ/year. The heat recovery wheel managed to reduce the CWC load by 56%, subsequently reducing the energy consumption of chiller by the same factor. With a heat recovery wheel, the incoming fresh air is pre-cooled sensibly along with moisture removal, which substantially reduces the load in the cooling coil. The average air DBT supplied to the cooling coil after pre-cooled in heat recovery wheel is 22.5°C at an average RH of 67% as indicated in Table 3.

Table 3 Comparison of supply air conditions to the cooling coil after passing through the heat recovery devices

<b>Heat Recovery Device</b>	<b>Average DBT (°C)</b>	<b>Average RH (%)</b>
<b>Heat Recovery Wheel</b>	22.5	66.8
<b>Heat Pipe Heat Exchanger</b>	22.9	95.8

It can be noticed that with the incorporation of a heat recovery wheel in the system, the total annual operating cost to maintain the room conditions in the OT can be reduced to USD7,663, which is a substantial decrease of 34%, saving an amount of USD3,437 per year.

### Plant C

The average air DBT supplied to the cooling coil after pre-cooled in HPHX is 22.9°C at an average RH of 96% (shown in Table 3). It is noticed that heat recovery wheel has lower air RH since it can recover latent load while HPHX used in this research will only recover sensible heat. However, one of the advantages of using HPHX is that it can reduce the energy consumption for reheating the overcooling air since the off-coil air from the cooling coil is reheated to a higher supply air temperature by the HPHX itself at the HPHX condenser.

It is pertinent to mention that the total energy consumption considers only the power consumed by the AHU fan, electric heater and the chiller only since the HPHX does not require external energy to drive its operation. However, the air pressure drop across the HPHX has to be accounted for in the additional AHU fan power consumption needed to maintain the required air change in the room.

It can be seen that the total annual energy consumption is 123410.97 kWh, which is an amount of USD8,022 annually spent on keeping the desired room conditions at the rate of USD0.065/kWh.

With the installation of a HPHX in the baseline model, the annual total cooling coil load can be reduced by 16% which is not as substantial as the reduction caused by a heat recovery wheel. This is mainly attributed to the efficiency of the equipment in recovering energy. Note that HPHX normally has lower efficiency in the range of 45% – 65% while heat recovery wheel has relatively higher efficiency of 50% – 85% (ASHRAE, 2004).

The simulation results (Table 2) suggests that heat recovery wheel has greater potential to recover energy from the exhaust air and hence substantially reduces the electricity cost of operation for the OT. From the simulation results, the annual saving by HPHX is USD8,022, which is the decrease by 28% of the baseline operating cost. However, the annual savings by the heat recovery wheel is USD7,663, which is approximately 31% of the baseline operating cost. Therefore, the results indicate that both heat recovery devices provided significant energy savings in the tropical HVAC systems operating at the operating theatre.

## **CONCLUDING SUMMARY**

From the baseline model, two redesign models have been successfully developed. The first redesign employs a heat recovery wheel while the other one uses a HPHX. The results of the study show that both heat recovery wheel and HPHX have great potential of reducing energy consumption of the current system in the tropics. Total energy consumption of the current system was estimated to be 170771 kWh while the energy consumption for the two redesign systems, heat recovery wheel and HPHX, were found to be 117899 kWh and 123411 kWh respectively.

In short, the heat recovery wheel manages to reduce the annual energy usage by 31% while the HPHX by 28%. Based on the findings in this research, it is recommended that both heat recovery devices could be incorporated into HVAC systems in tropical operating theatres as they have remarkable potential for energy savings.

## **ACKNOWLEDGEMENTS**

The authors would like to acknowledge the full financial assistance from the Ministry of Science, Technology and Innovation (MOSTI), Malaysia, via e-Science Fund Project 13-02-03-3034 for research work to be conducted in University of Malaya, Kuala Lumpur, Malaysia. In addition, special thanks are extended to Mr. Chea S.K., General Manager at Carrier (MALAYSIA) Pte. Ltd., for his help during critical portions of the project.

## **REFERENCES**

- ASHRAE (2004) ASHRAE Handbook – HVAC Systems and Equipment. Chapter 44 Air-to-Air Energy Recovery. American Society of Heating, Refrigerating, and Air-Conditioning Engineers Inc., Atlanta, GA.
- Balaras, CA; Dascalaki, E; Gaglia, A (2006) HVAC and indoor thermal conditions for hospital operating rooms. *Energy and Buildings* 39 (2007) 454-470.
- Chea S.K. (2008) Carrier (MALAYSIA) Pte. Ltd., Kuching. Private Communications.

- Klein S. Beckman W.A., Mitchell et. al. (2004) A Transient System Simulation Program. Solar Energy Laboratory, University of Wisconsin—Madison, Madison, WI 53706 USA.
- Lim D.C.B. (2008), Redesign of HVAC Systems to Resolve Fungus Growth Problem and Energy Savings for a Private Hospital. B.Eng. (Hons) in Mechanical Engineering Thesis. Department of Mechanical Engineering, University of Malaya.
- Lim P.H. (2008) Bry Air (MALAYSIA) Pte. Ltd., Petaling Jaya. Private Communications.
- National Energy Board, Malaysia (2008). Tenaga Nasional Berhad Tariff Rates. <http://www.tnb.com.my/newtnb/custom/tr/et1.html>. DOA: 7/4/2008.
- S&P Coil Product Limited (2008) Self-Selection Software, Product Information and Professional Development. <http://www.spcoils.co.uk>. DOA: 2008-2-24.
- Yau Y.H. (2008) The use of a double heat pipe heat exchanger system for reducing energy consumption of treating ventilation air in an operating theatre-A full year energy consumption model simulation. *Energy and Buildings*, 40 (5), 917-925.