

## EXPERIMENTAL TEST OF A NEW DEDICATED NATURAL GAS ENGINE

Masjuki H.H<sup>1</sup>, M.A. Kalam<sup>1</sup>, A. Ishak<sup>2</sup>, M. Khair<sup>2</sup>, A. Shahrir<sup>3</sup> and A. Yusof<sup>3</sup>

<sup>1</sup>Department of Mechanical Engineering, University of Malaya, 50603 Kuala Lumpur, Malaysia

<sup>2</sup>Department of Electrical and Electronic Engineering, Universiti Putra Malaysia, Serdang, Selangor, Malaysia

<sup>3</sup>Department of Mechanical and Materials Engineering, University of Kebangsaan Malaysia, 43600 Bangi Selangor, Malaysia

Email: kalam@um.edu.my

### ABSTRACT

*This paper presents experimental test results of a new compressed natural gas direct injection (CNG-DI) engine that has been developed from modification of a multi cylinder gasoline port injection (PI) engine. The major modifications done are (1) the injection system has been modified to gas direct injection using new high pressure gas injectors, (2) compression ratio has been changed from 10 to 14 through modification of piston and cylinder head, and (3) new spark plugs with long edge were used to ignite the CNG fuel. The CNG pressure at common rail was kept at 20 bar to be injected into engine cylinder. The engine has been operated with full throttle conditions to compare all the results with original base engine such as gasoline port injection engine and the CNG bi-fuel engine where the base engine has been converted to bi-fuel injection system to be operated with gasoline and CNG fuels. Hence, it can be mentioned that the original gasoline port injection engine has been modified to CNG bi-fuel and CNG-DI systems. The bifuel injection was developed using a gas conversion kit with gas port injection injectors. The test results obtained from CNG fuel using two different systems (i.e. bi-fuel and DI) will be investigated and compared with original gasoline engine. The test was conducted with computer controlled dynamometer to measure brake power, specific fuel consumption (SFC), exhaust emissions such as carbon monoxide (CO), oxides of nitrogen (NOx), and unburned hydrocarbon (HC). The objective of this investigation is to compare the test results between "CNG-DI", with "CNG-BI" and "gasoline - PI" engines with the same displacement volume. It was found that the CNG-DI engine produces 4% higher brake power at 6000 rpm as compared to original gasoline fueled engine. The CNG-BI engine produces maximum power of 57 kW at 5500 rpm which is 23% lower than CNG-DI engine's peak power (at 6000 rpm). The average BSFC of CNG-DI engine was 0.28% and 8% lower than gasoline-PI and CNG-BI engines respectively. The CNG-DI engine reduces 50% NOx emission as compared to base engine. However, the CNG-DI engine produces higher HC and CO emissions as compared to base engine by 34% and 48% respectively. The results of this experiment will be used for further improvement of the CNG-DI engine as well as to develop a new CNG-DI car.*

**Keywords:** DI Engine; CNG-BI engine; Power; SFC; Emissions.

### INTRODUCTION

Compressed Natural Gas Direct Injection (CNG-DI) engine development has now become a challenging and innovative technology. In particular, automotive engine researchers have sought this technology to improve engine efficiency with natural gas fuel to meet stringent emission limits. This innovative development will reduce emission to limit the negative impact of the green house effect.

This investigation is new and with an accelerating effort to design and develop better efficient engines while researchers have devoted significant resources to developing a CNG-DI engine. It is believed that CNG-DI engine has great potential to optimize fuel supply and combustion, which in turn can deliver better performance and lower fuel consumption. Until now, no one has successfully designed an in-cylinder direct injection (with Otto cycle) CNG-DI engine for use on production vehicle. However, many researchers have conducted works on CNG-DI system for diesel engine as in Ref [1-6]. Hence, the output of this investigation and developing capabilities for advanced CNG-DI engine using gasoline cycle with SI system will be a realization of engineering dream.

## Reason for CNG-DI Engine

In conventional fuel injection system natural gas is injected into engine cylinder either by a mixer, single-point injection or multipoint injection with electric motors. However in all the above system, natural gas engine produces lower brake power as compared to gasoline fuel. Hence, CNG-DI engine system is more suitable where the fuel is injected through high pressure pipe line straight into the cylinder with the required amount to produce similar or higher brake power than a gasoline engine.

With the recent increase of oil price, it becomes necessary to accelerate the use of NG especially for the automotive sector. Therefore, new technologies encompassing fuel systems, combustion chambers, control units, vehicle body, fuel storage and refueling infrastructure need to be developed.

## Fuel Injection System Classification

Many car companies have proposed and developed dedicated natural gas engine during the last ten years and most of them are MPI system, where the engine thermal efficiency is low and TWC is utilized to reduce emissions. However, some researchers like Westport Innovations Inc. and ISUZU car company (Japan) have proposed and developed CNG-DI engine based on diesel cycle combustion system [1-3]. It was proposed [1-3] that natural gas direct injection and shielded glow plug ignition with hot surface system mounted on cylinder head would improve engine efficiency. However, based on ISUZU CNG-DI engine, an attempt was undertaken to produce dedicated natural gas engine to replace diesel fuel. In this investigation, CNG-DI engine has been proposed to replace gasoline fuel and combustion system. It is developed based on Otto cycle with spark plug ignition. The following figure (Fig.1) shows various combustion systems for CNG fuel. From the Figure, it can be explained that each combustion system has unique features to reflect specific strategies of mixture preparation, combustion control and emissions reduction. However, all systems have a common goal of achieving substantial fuel economy improvement while simultaneously achieving large reductions in engine output and tailpipe emissions.

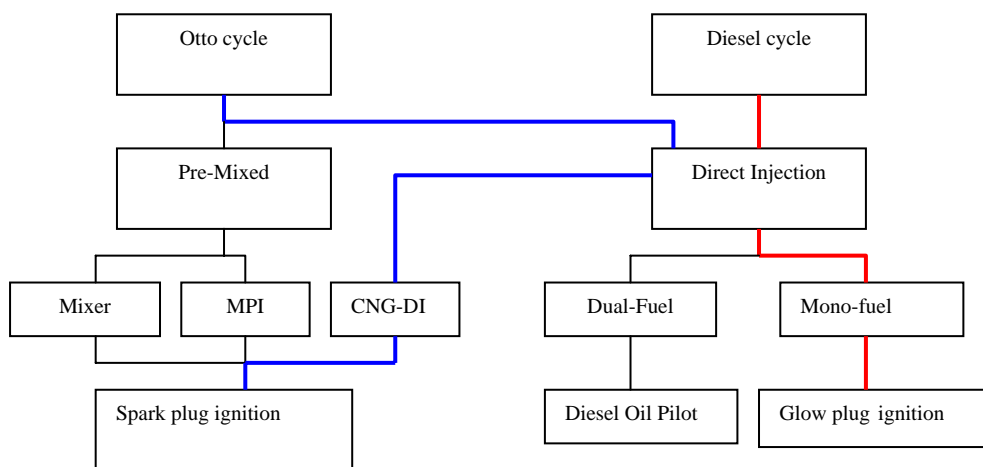

Figure 1: Various Combustion Systems for CNG Fuel

The main objectives of this investigation are to experimentally investigate the performance and emissions characteristics of a newly developed compressed natural gas direct injection (CNG-DI) engine under various test conditions. Secondly, to study on benchmarking between CNG-DI engine with gasoline port injection (Gasoline –PI) and CNG bi-fuel (CNG-BI) engines when the displacement volume is same for all the cases.

## PROCEDURE

A schematic diagram of the experimental setup is shown in Fig.2. A total of three engines were tested and their specifications have been shown in Table 1. The CNG-DI engine was developed through modification of a gasoline engine (gasoline-PI engine). The major modifications done are – (1) Increasing compression ratio from 10 to 14 through modifying piston and cylinder head, (2) new spark plugs with long edge were used to ignite the

CNG fuel and (3) Fuel injection system was modified from MPI to DI system. The CNG injection pressure was 20 bars at the common rail. The temperature of CNG at the common rail was found 16°C.

The injector was designed to inject CNG fuel into the engine cylinder. The injector was initially set with a spring preload of 38 N. The spring preload was then adjusted with  $\pm 1$ N to trim the dynamic flow at 100 Hz with 2.0 msec pulse width. The average stroke length, dynamic flow rate, opening and closing time are 0.267 mm, 19.06 mg/shot, 1.50 msec and 0.93 msec respectively. An eddy current dynamometer with maximum absorption power of 150 kW was used to maintain the variation of loads at different engine speeds. The dynamometer could be started, loaded and monitored via remote operation of the control-instrumentation unit and data acquisition control system. The dynamometer was also equipped with speed sensor, switches for low pressure and high temperature for cooling water, the drive shaft, water inlet valve and load cell torque measurement unit. The air flow rate into the engine inlet manifold was measured by a hot-wire anemometer (accuracy  $\pm 0.2\%$ ) which comes with the engine. A hot-wire anemometer keeps the temperature of a thin wire constant by adjusting the current flow through the wire. The current required to keep the temperature constant depends on the convective heat transfer, which depends on the mass airflow past the wire. This air mass flow meter data is transferred to a analog input card through a signal cable of 0-5 volts. Finally, the actual airflow into the engine was analyzed from the data logged (Cadet 12 engine controlled software) into the computer. The coriolis micro motion mass flow meter was used to measure CNG flow rate into engine. The water and lubricant temperatures were controlled at 80°C and 90°C respectively. Horiba exhaust gas analyzer was used to measure emissions concentration for CNG-DI engine. This analyzer was interfaced with main engine controlled software (CADET12), so that all the emissions data and engine operating data can be logged at the same time for analysis. These analyzers consist of individual module of each emission parameters and have zero and span gas calibration facility. The measurement technique of the analyzer is infrared for CO, CO<sub>2</sub> and HC while chemiluminescent for NO<sub>x</sub> emissions. Details working principle can be seen in HORIBA website.

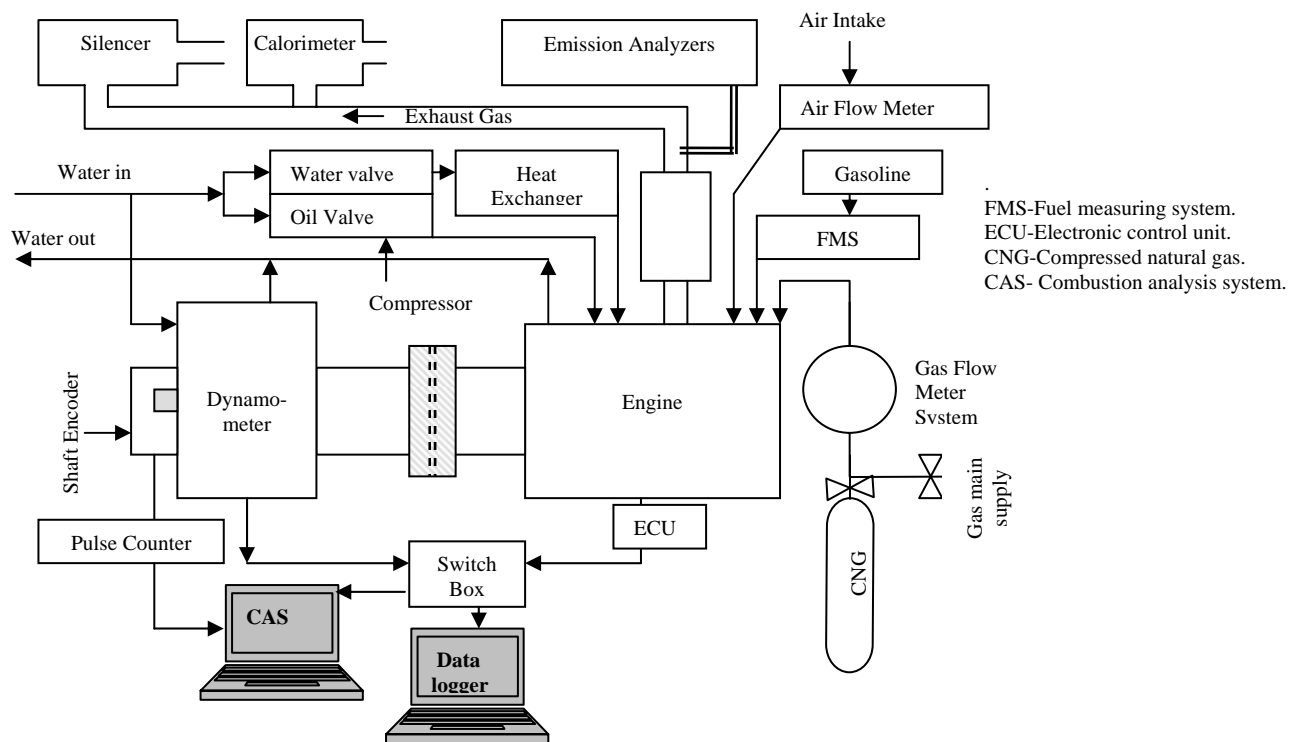

Figure 2: Schematic Diagram of the Experimental Set-Up

MOTEC professional lambda meter was used to measure exhaust air fuel ratio to be tuned up by ECU. It accurately determines exhaust gas mixture strength over a wide range of engine operating conditions with a fast response time. The operating range of the device (MOTEC lambda meter) is between 0.70 to 32.00 lambda and the air fuel ratio range of a typical spark ignition engine is about 10 to 22 (which is within the measurable range of OEM lambda meter). Hence, for CNG-DI engine development, MOTEC lambda meter was good enough to tune up the engine configuration to achieve maximum best torque (MBT). MOTEC accurately determines only one mixture strength to achieve best performance.

The combustion analysis system (CAS) includes control software, encoder and pressure sensors [7]. Other sensors (a total of 9 thermocouples and 6 pressure sensors) were installed into the engine test bed to measure

temperature and pressure at various test point. The instrument used in this investigation was fully equipped in accordance with SAE standard J1349 JUN90 (ref. SAE Handbook 2002). All the engines were tested from 1500 rpm to 6000 rpm with wide open throttle (WOT) condition for comparisons purposes.

Table 1: Test Engines Specifications

Item	Gasoline-PI*	CNG-BI	CNG-DI
Bore x stroke (mm)	76x88	76x88	76x88
Displacement (cc)	1597	1597	1597
Number of cylinder	4	4	4
Compression ratio	10	10	14
Combustion chamber	Bowl	Bowl	Bowl
IVO (BTDC)	12°	12°	12°
IVC (ABDC)	48°	48°	48°
EVO (BBDC)	45°	45°	45°
EVC (ATDC)	10°	10°	10°
Fuel system	MPI	bi-fuel	CNG-DI
Rated power (kW/rpm)	82/6000	82/6000	82/6000
Rated torque (Nm/rpm)	148/4000	148/4000	148/4000
Fuel pressure (bar)	3.25	3.25	20
Valve train & cylinder configuration	DOHC 16V 4 cylinders in-line	DOHC 16V 4 cylinders in-line	DOHC 16V 4 cylinders in-line

\* is the base engine for CNG-DI and CNG-BI engine.

### Fuels used in this investigation

The composition of a natural gas fuel varies with location, climate and other factors. It is anticipated that such changes in fuel properties affect emission characteristics and performance of CNG fuel in engines as shown by [7,8].The physicochemical properties of CNG and gasoline fuels used in this experiment are shown in Table 2 and Table 3 respectively. The lube oil used was ordinary commercial lube oil (SAE 40).

Table 2: Natural Gas Compositions

Component	Mole(%)
Methane	94.42
Ethane	2.29
Propane	0.03
Isobutane	0.23
Normal-butane	0.02
isopentane	0.01
Hexane	0.01
Carbon dioxide	0.57
Nitrogen	0.44
Others	-

Table 3: Physicochemical Properties of CNG and Gasoline Fuels

Properties	CNG	Gasoline
Density (kg/m <sup>3</sup> )	0.81	-
Gross calorific value (MJ/kg)	49.00	45.00
Molecular weight	16.69	114.00
Specific gravity	0.64 (compared to air)	0.692 (compared to water)

## RESULT AND DISCUSSIONS

The engine test room temperature was about 25°C. The compressed natural gas direct injection (CNG-DI) engine did not have any initial starting difficulties due to fuel ignited by spark plug. In this investigation, total three engines have been tested such as (1) “Gasoline-PI” gasoline fuel with port injection system engine, (2) “CNG-BI” compressed natural gas fueled engine with bi-fuel injection system, and (3) “CNG-DI” compressed natural gas engine with direct injection system. These three engines have same cylinder volume i.e. 1.6 litres. The results showed in this paper are obtained from WOT with variable speed condition. All the results obtained from experimental tests are discussed as follows:

### Brake power at WOT

Figure 3 shows brake power versus engine speed from 1500 rpm to 6000 rpm for all the test engines such as “Gasoline-PI”, “CNG-BI” and CNG-DI engines at WOT. The gasoline-PI and CNG-DI produce maximum brake power at 6000 rpm which are 70.21 kW and 73.04 kW respectively. However, the CNG-BI produces maximum brake power at 5500 rpm which is 57.35 kW (23% lower than CNG-DI engine). The average brake power over the test cycle obtained was 48.50 kW, 36.90 kW and 45.37 kW by “Gasoline-PI”, “CNG-BI” and CNG-DI engines respectively. The CNG-DI engine produces 2.83 kW (4%) higher brake power at 6000 rpm but on average all over the engine speed range it reduces 2.02 kW brake power as compared to base engine “gasoline-PI”.

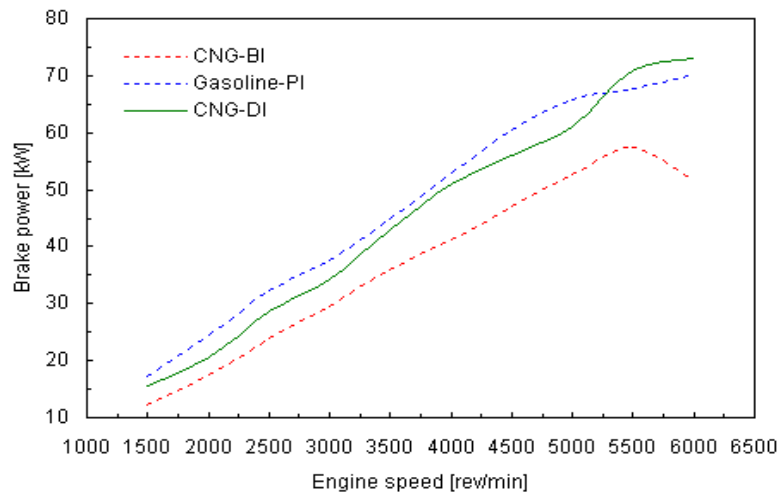

Figure 3: Brake Power Versus Engine Speed at WOT

The reason of producing lower brake power from CNG-DI engine is mainly due to producing lower brake torque which is strongly related to volumetric efficiency, gas inlet temperature, gas mixture distribution, AFR as well as cylinder pressure. However, after 5000 rpm, the CNG-DI engine produces higher brake power which might be due to increasing fuel conversion efficiency. On average all over the speed range, the CNG-DI engine produces 22.95% higher brake power than CNG-BI engine.

### Brake torque at WOT

Figure 4 shows brake torque versus engine speed from 1500 rpm to 6000 rpm for all the test engines such as “Gasoline-PI”, “CNG-BI” and CNG-DI engines at WOT. It is found that “Gasoline-PI”, “CNG-BI” and CNG-DI produced their maximum torque are 128.42 Nm (at 4500 rpm), 100 Nm (at 4500 rpm) and 123.47 Nm (at 5500 rpm) respectively. The average brake torque over the test cycle for “Gasoline-PI”, “CNG-BI” and CNG-DI engines obtained are 120.54 Nm and 92.36 Nm and 108.25 Nm, respectively. The reason of producing lower brake torque by CNG-DI engine is mainly due to lack of chemical energy conversion to mechanical energy which is strongly related to volumetric efficiency, fuel mixing, net heat release rate as well as cylinder pressure. Improper cylinder pressure such as too high or too low cylinder pressure causes lower brake torque. However, the CNG-BI shows the lowest level of brake torque production as compared to CNG-DI and gasoline-PI systems.

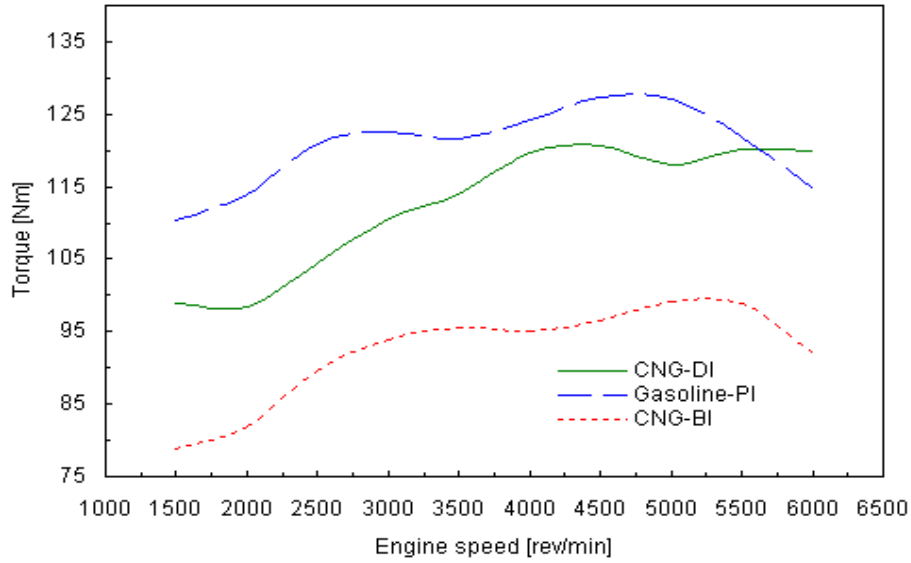

Figure 4: Brake Torque Versus Engine Speed at WOT

### Brake specific fuel consumption at WOT

Figure 5 shows the variation of brake specific fuel consumption (BSFC) versus engine speed for all the test engines from 1500 rpm to 6000 rpm at WOT. It can be seen that the BSFC increases initially at 1500 rpm for all the engines due to increase in magnitude of friction, pumping work and the increased relative importance of friction and heat transfer, which decreases the gross indicated fuel conversion efficiency [4].

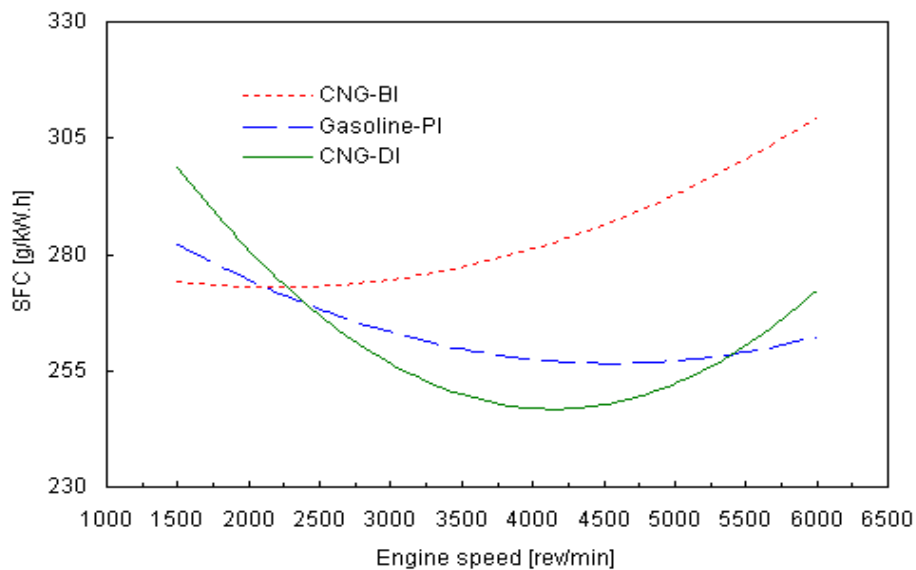

Figure 5: Brake Specific Fuel Consumption Versus Engine Speed at WOT

It is found that “Gasoline-PI” engine reduces SFC from 1500 rpm to 3500 rpm due to increasing fuel conversion efficiency and then started to increase SFC due to increasing frictional effect with increasing engine speed. However, the average SFC of CNG-DI engine is lower than “Gasoline-PI” as well as “CNG-BI” engines. The lowest SFC (243.34 g/kWh) comes from the CNG-DI engine at 3500 rpm followed by “Gasoline-PI” (254.87 g/kWh@3500 rpm) and “CNG-BI” (264.11 g/kWh@3500 rpm) engines. The average SFC over the test cycle for “CNG-DI”, “CNG-BI” and “Gasoline-PI” engines are 263.26 g/kWh, 284.26 g/kWh and 264 g/kWh respectively.

## Exhaust emissions

### Unburned hydrocarbon at WOT

Unburned hydrocarbon or partially oxidized hydrocarbon emission increases if (a) the injection occurs too early, in which case the delay time increases with the result that more fuel goes to contact at the relatively cool cylinder wall, or (b) injection too late in which case there may be insufficient time for completion of combustion. The later case may be matched with CNG-DI engine as the direct injection cooled gas entering into engine cylinder, which is the main reason for the increase of HC emission as compared to “gasoline-PI” engine. It is found that however, the maximum level of HC is produced by “CNG-BI” engine followed by CNG-DI and “gasoline-PI” engines (Fig.6). The average HC emissions over the entire test cycle were 137 ppm, 102 ppm and 203 ppm by CNG-DI, “Gasoline-PI” and “CNG-BI” respectively. The CNG-DI engine produces slightly higher (by 34%) than the base engine “gasoline-PI”. This finding such as the increasing of HC by the natural gas engine matches with another investigation [10].

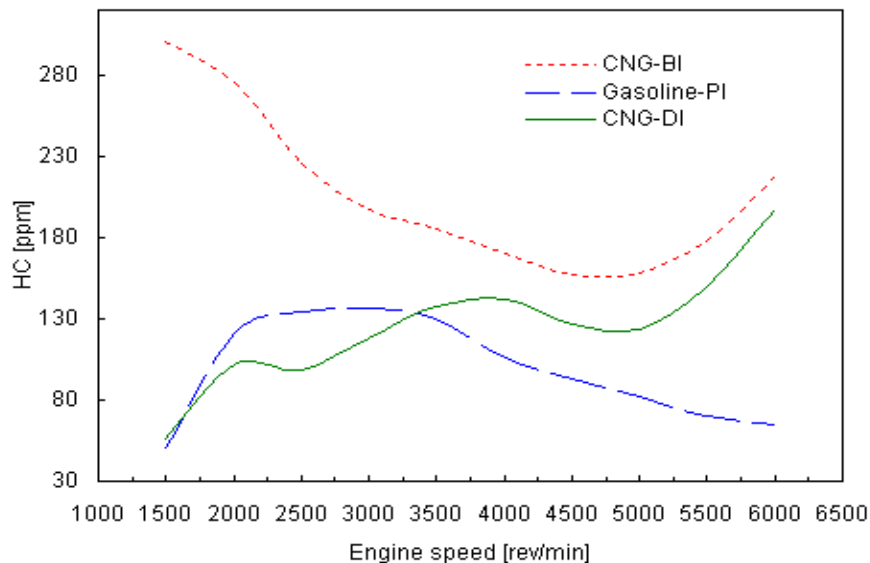

Figure 6: Unburned Hydrocarbon Versus Engine Speed at WOT.

### Oxides of nitrogen at WOT

The main cause for the increase of NO<sub>x</sub> is high combustion temperature [11]. The NO<sub>x</sub> concentration versus engine speed is illustrated in Fig. 7. It was found that the lowest NO<sub>x</sub> was produced by “CNG-BI” (average 489 ppm) followed by CNG-DI (809 ppm) and “gasoline-PI” (1526 ppm) engine. It is very interesting that the CNG-DI reduces (50%) NO<sub>x</sub> emissions as compared to base engine “gasoline-PI”. This is mainly due to cool gas entering into engine cylinder, so that the overall combustion is completed at low in cylinder temperature. The CNG temperature at common rail is 16°C, and the intake temperature is about 35°C which gives lower combustion temperature, hence the NO<sub>x</sub> reduction. The maximum NO<sub>x</sub> at 2430 ppm was produced by “gasoline-PI” engine at 6000 rpm. The CNG-DI engine produces maximum NO<sub>x</sub> emission (1386 ppm) at 6000 rpm and overall NO<sub>x</sub> emissions level is lower than “gasoline-PI” engine by 717 ppm. Hence, it is an important finding that modification from gasoline/MPI system to CNG-DI system reduces NO<sub>x</sub> emissions.

### Carbon monoxide at WOT

Carbon monoxide (CO) is formed during the combustion process with rich fuel-air mixtures and when there is insufficient oxygen to fully burn all the carbon in the fuel to CO<sub>2</sub>. As CO is strongly related to rich fuel-air mixtures, hence spark ignition engine is the significant sources for CO emission, because they use stoichiometric or close to stoichiometric air-fuel ratio which may divide into fuel rich zone and fuel lean zone in the cylinder during combustion. The rich zone increases CO emission. Hence, increasing CO emission refers to as incomplete combustion of fuel. It is found that “CNG-DI” engine produces higher CO (Fig. 8) emission from engine speed 2500 to 6000 rpm while decreases NO<sub>x</sub> emissions (Fig.11). This is mainly due to rich fuel-air mixture which gives low temperature combustion as compared to “gasoline-PI” engine. However, the CNG-DI

shows slightly higher CO emission ((48%) mainly due to rich mixture which comes from low volumetric efficiency. The results indicate that fuel mixing and burning rate are the main problems for CNG-DI system, where some fraction of fuel goes out from engine cylinder as unburned hydrocarbon and some fraction is burning completely to CO<sub>2</sub>. Over the test cycle, it can be seen that “CNG-DI” engine produces higher CO (2.01%) emission followed by “CNG-BI” (1.31%) and gasoline-PI (1.11%) engine.

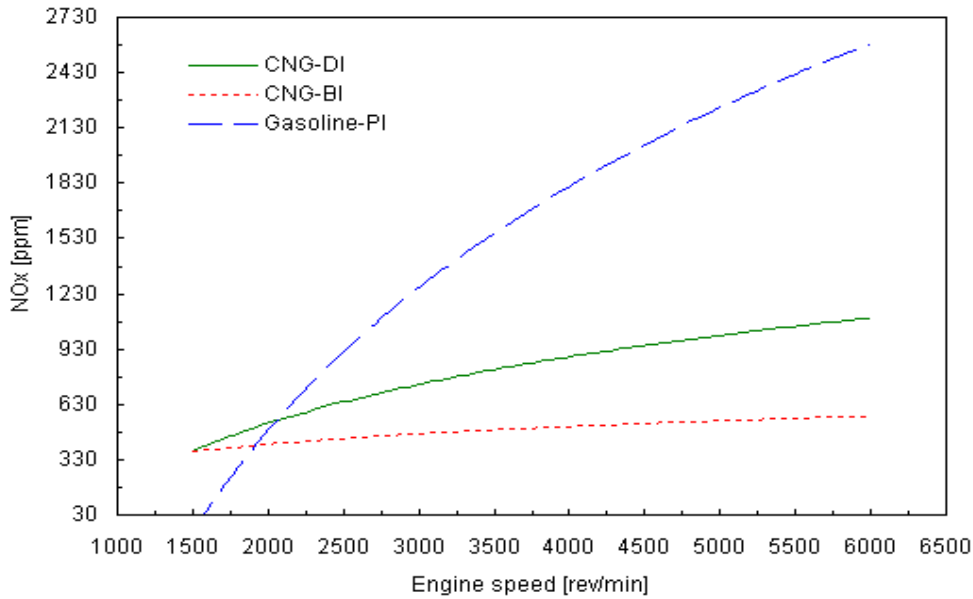

Figure 7: Oxides of Nitrogen Versus Engine Speed at WOT

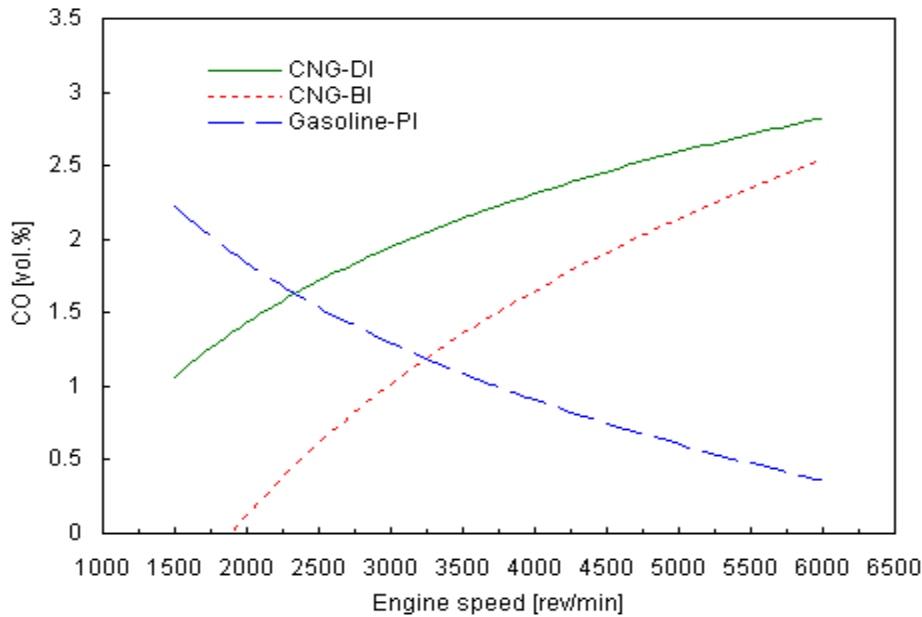

Figure 8: Carbon Monoxide Versus Engine Speed at WOT

## CONCLUSION

The CNG-DI engine did not have any initial starting difficulties due to fuel ignited by spark plug. The engine did not show any combustion noise at compression ratio of 14 (initial compression ratio was 10). The following conclusions may be drawn from the present investigation:

1. The CNG-DI, “Gasoline-PI” and “CNG-BI” engines produced maximum brake power are 73.04 kW (at 6000 rpm), 70.21 kW (at 6000 rpm) and 57 kW (at 5500 rpm) respectively at WOT. The CNG-DI produces 4% and 23% higher brake power as compared to base engine “gasoline-PI” and “CNG-BI” engines respectively.



2. The CNG-DI engine reduces 50% NO<sub>x</sub> emission as compared to original base gasoline engine such as gasoline-PI system.
3. The CNG-DI engine produces higher HC and CO emission as compared to base engine "gasoline-PI" by 34% and 48% respectively.

In general, it can be stated that CNG-DI engine performs better than gasoline-PI and CNG-BI engines.

## ACKNOWLEDGEMENTS

The authors would like to thank Mr. Sulaiman Bin Ariffin (Laboratory Assistant), Muhammad Redzuan bin Umar (Research Assistant) and Mohd Khair bin Hassan (Research assistant from UPM) for providing special technical assistance related to engine test bed, ECU calibration and data collections. Without their help, it was very difficult to complete the engines test. A special acknowledgement is also offered to the University of Malaya and the Ministry of Science, Technology and Innovation for the research grant of this project through Vote- IRPA No: 33-02-03-3011. The authors would like to thank UPM, UKM, UiTM, UTP and Proton Berhad which successfully to produce the new CNG-DI engine through collaborative research works. In addition, the authors would like to thank JSPS for travel grant.

## REFERENCES

- [1] Sandeep M., Patric O., James H., Costi N., Jeff T. and Stewart W. (2002) Direct Injection of Natural Gas in a Heavy-Duty Diesel Engine, SAE paper no: 2002-01-1630.
- [2] Dale G., Mark D., Sandeep M., Edward L. P., John Wright, Vinod Duggal and Mike Frailey. (2004) Development of a Compression Ignition Heavy Duty Pilot-Ignited Natural Gas-Fuelled Engine for Low NO<sub>x</sub> Emissions, SAE paper no: 2004-01-2954.
- [3] Michael R. F., Edward L.P., Mostafa M. K., Scott Wayne, Ralph D. Nine, Nigel N. Clark and Michael S. Bolin. (2002) An Emission and Performance Comparison of the Natural Gas Cummins Westport Inc. C-Gas Plus Versus Diesel in Heavy- Duty Trucks, SAE paper no: 2002-01-2737.
- [4] Hill, P.G. (2000) Analysis of Combustion in Diesel Engines Fueled by Directly Injected Natural Gas, ASME Journal of Engineering for Gas Turbines and Power, Vol. 122, pp. 141-149, January 2000.
- [5] Hodgins, K.B., Ouellette, P., Hung, P., and Hill, P.G. (1996) Directly Injected Natural Gas Fueling of Diesel Engines, SAE Paper No. 961671.
- [6] Mtui, P.L., and Hill, P.G. (1996) Ignition Delay and Combustion Duration with Natural Gas Fueling of Diesel Engines, SAE Paper No. 961933.
- [7] Kalam, M.A. (2007) Performance and simulation study of a compressed natural gas direct injection engine, Ph.D. Thesis, University of Malaya, Malaysia.
- [8] Byung, H.M.; Chung, J.T.; Kim, H.Y. and Simsoo, P. (2002) Effects of gas composition on the performance and emissions of compressed natural gas engines, KSME International Journal, Korea, 16(2), pp. 219-226.
- [9] Heywood, John. B. (1988) Internal Combustion Engine Fundamentals, Mcgraw-HILL International Editions.
- [10] Ke Zeng, Zuohua Huang, Bing Liu, Liangxin Liu, Deming Jiang, Yi Ren, Jinhua Wang. (2006) Combustion characteristics of a direct-injection natural gas engine under various fuel injection timings, Applied Thermal Engineering, Vol. 26, pp.806-813.
- [11] Bittner, R.W. and Aboujaoude, F.W. (1992) Catalytic control of NO<sub>x</sub>, CO and NMHC emissions from stationary diesel and dual fuel engines, Journal of engineering for gas turbines and power, July 1992, Vol.114, pp.597-601.